

Installation and Operating Instructions

JUDO PROMI

Sizes $\frac{3}{4}$ " - 2"

Valid for: Canada

Attention:

Carefully read through the installation and operating instructions and safety information before installing and putting the unit into service.

These instructions must always be issued to the owner/user.

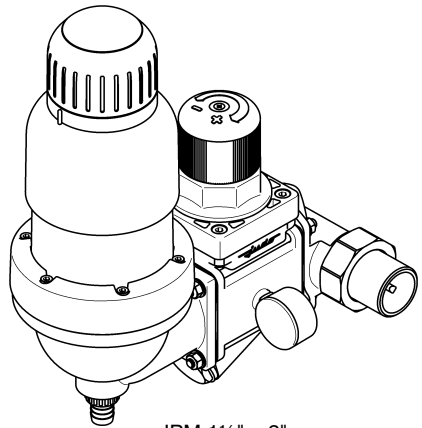

JPM 1 1/2" - 2"

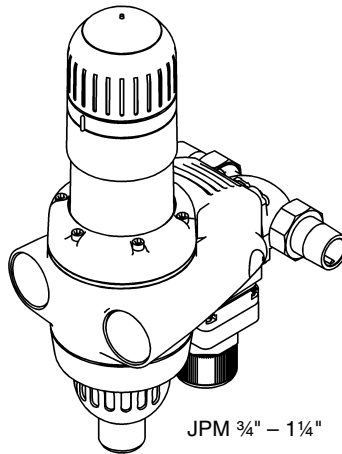

JPM $\frac{3}{4}$ " - 1 1/4"



Corporate head office

JUDO Wasseraufbereitung GmbH
P.O. Box 380
D-71351 Winnenden
Germany
e-mail: info@judo.eu
judo.eu

Manufacturing plant

JUDO Wasseraufbereitung GmbH
Hohreuschstraße 39-41
D-71364 Winnenden
Germany

Dear Customer,

we would like to thank you for choosing JUDO Water Treatment.

The product you have purchased is the JUDO PROMI domestic water station, which is to be utilized in domestic drinking water applications/ installations for:

- **filtration,**
- **pressure reduction,**
- **and backflow prevention.**

The JUDO PROMI is suitable for use in COLD water applications only, up to a water temperature of maximum 30 °C (86 °F) and up to a water pressure of maximum 232 psi (1600 kPa). It filters out all coarse and fine-grained physical impurities/particles from the water supply, which are larger than or equal in size to the filter cartridge/ sieve pore size. An inlet water pressure of maximum 232 psi can be reduced to an outlet water pressure of 22 psi, as a minimum, with all psi pressure ranges in between. The Factory-Setting is 58 psi. As backflow prevention the JUDO PROMI is equipped with a spring-loaded check-valve.

The JUDO PROMI has been developed using leading edge and state-of-the-art technologies; each unit has been thoroughly inspected prior to packaging and delivery. If you encounter any installation or performance problems, please do not hesitate to contact our customer service department. Our local phone number and website is listed on the back page.

Trademarks:

Trademarks used in this document are protected and registered trademarks of the respective holder.

© JUDO Wasseraufbereitung GmbH
D-71364 Winnenden

All rights reserved.
Reprints – even of extracts – are only permitted with special written approval.

BEFORE YOU BEGIN

- Inspect carton and product carefully and thoroughly for defects or shipping damage.
- Turn off the main water supplies.
- Use this product in accordance with all the respective local regulations, codes and safety practices.
- Do not install this product in applications where the ambient temperature is below 4 Celsius.
- Do not install this product closer than 13 feet (4 m) of plumbing piping between the filter outlet and the inlet of any water heater. Water heaters can and will transmit heat back through its respective plumbing. Always ensure that this product is installed so that the water temperature never exceeds a maximum of 30 °C (86° F) for all applications. If in doubt, always check with local plumbing and building authorities prior to installation.
- Do not install in applications where exposed to direct sun radiation/ sun light.
- Do not expose this product to solvents or cleaners containing alcohol or petroleum products.
- Do not install this product near acid or acid fumes.
- All plumbing MUST conform to local codes.
- All plumbing must be properly supported with no stress to be put on product or piping.

Table of Contents

1. About this Instruction Manual..... 4

 1.1 Symbols used 5

 1.2 Safety information and dangers due to non-compliance 5

 1.3 Units used..... 5

2. Intended use 6

 2.1 Water Pressure..... 6

 2.2 Notes on special dangers 6

3. Product Information 7

 3.1 Intended purpose..... 7

 3.2 Test mark..... 7

 3.3 Materials used 7

4. Installation 8

 4.1 General..... 8

 4.2 Discharging backwash water 10

5. Operation 12

 5.1 Commissioning 12

 5.2 Pressure Setting..... 12

 5.3 Function Description..... 13

 5.4 Backwashing 14

 5.5 Modifications / changes / spare parts..... 15

 5.6 Stoppages 16

6. Faults 17

7. Maintenance..... 17

 7.1 Cleaning 17

 7.2 Checking the note electronics (only JPM ¾" - 1¼")..... 18

 7.3 Filter sieve 18

8. Warranty and Services..... 18

9. Data Sheet..... 19

 9.1 Type..... 19

 9.2 Models 19

 9.3 Technical Data..... 19

 9.4 Installing dimensions JPM ¾" - 1¼"..... 20

 9.5 Installing dimensions JPM 1½" - 2"..... 21

 9.6 Extent of Supply 21

10. Spare Parts 22

 10.1 JPM ¾" - 1¼"..... 22

 10.2 JPM 1½" - 2"..... 25

11. Customer Service..... 28

1. About this Instruction Manual



(see chapter "Safety information and dangers due to non-compliance")

The instruction manual must be permanently available at the place in which the filter is installed and used.

This instruction manual is intended to make it easier to familiarize yourself with this filter.

The instruction manual contains important information in order to safely, properly and economically operate this filter.

This instruction manual contains fundamental information, which must be observed during installation, operation and maintenance. Observance of this information helps to avoid dangers, reduce repair costs and increase the reliability and service life of the filter.

The instruction manual must be read and used by each person entrusted with carrying out work on the filter, for example and not limiting to:

- **Installation**
- **Operation**
- **Maintenance**
(servicing, inspection, repair)

Installation and maintenance may only be carried out by qualified personnel, who are capable of fulfilling the instructions given in the installation.

Therefore, this instruction manual must always be read by the fitter / Installer and responsible skilled personnel/owner or operator before installation, putting into service and maintenance.

All the general safety notes given in this instruction manual are to be observed and carried out safely. Failure to do so can result in personal injury and / or property damage.

The manufacturer waves all liabilities.

1.2 Safety information and dangers due to non-compliance

1.1 Symbols used

The safety notes contained in this instruction manual are labelled with the following symbols:



ATTENTION



Notes on possible dangers



Warning, electrical hazards.



Torques specified by the manufacturer.



Tips for use and other important information.

Notes that are directly attached to the filter housing, e.g.

- Direction of flow (see Fig.1)
- Rating plate
- Cleaning information

must always be observed and kept in a fully legible condition.

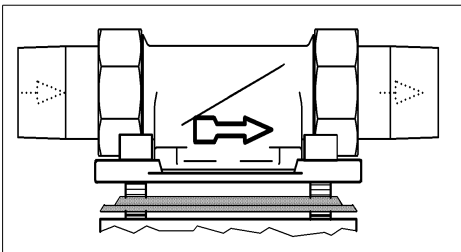

Fig. 1: Built-in rotary flange

In detail, failure to observe the general danger symbols can result, for example, in the following risks:

- Failure of important functions and features of this product.
- Danger to persons due to electrical and mechanical conditions.
- Danger to property and the environment due to leaks.

Refrain from any unsafe working methods.

1.3 Units used

In derogation of the International System of Units (SI = System International), the following units are used:

Units	Conversion
°F	$9/5 + 32 = °C$
1 bar	14,5 psi
¾"	20 mm
1"	25 mm
1¼"	32 mm
1½"	38 mm
2"	52 mm

2. Intended use

The installation and operation of the filter is subject to the following existing national regulations.

In addition to the operating instructions and the obliging regulations concerning accident prevention that exist in the country of operation and the location of use, the established technical regulations concerning safe and professional work, should also be observed.

The water to be filtered must be drinking water quality !

It is absolutely essential that the manufacturer / supplier will be consulted prior to any operation of the device using water of a different quality, respectively with water that contains additives.

This filter is suitable for use in cold drinking water up to a maximum water temperature of 30 °C (86 °F).

The filter has been developed and manufactured using state of the art technology and the established safety regulations in Germany.

The filter may only be operated in accordance with the manufacturer's specifications. Any other operation or operation beyond the specified use, is not in accordance with the manufacturer's specifications.

Additional dangers may result in the event of the device not being operated in accordance with the manufacturer's specifications and non-observance of the danger symbols or safety instructions. The manufacturer / supplier cannot be made liable for any damages caused by these additional dangers. The operator is responsible for these risks.

The use of the device in accordance with the customer's specifications includes the observance of the operating instructions.

The manufacturer / supplier should be consulted prior to any operation of the filter other than in the operational areas stated in these operating instructions.

The filter may only be operated in a technically faultless condition, in accordance with

the manufacturer's specifications and the stated safety and danger relevant instructions and under observance of the operating instructions!

Any functional defects are to be removed immediately!

2.1 Water Pressure

The water pressure should be between 22 psi (150 kPa) and 232 psi (1600 kPa).

The water pressure must not be below 22 psi (150 kPa) as otherwise the backwashing can be impaired! If the filter is not backwashed regularly a pressure loss can result and this can impair the filter function.



(see chapter "Safety information and dangers due to non-compliance")

In the event of **water pressure above 232 psi (1600 kPa)**, a pressure reducing valve should be fitted **in front** of the filter (see fig.4). If the operating pressure is above 232 psi (1600 kPa), this may result in defects during operation.

2.2 Notes on special dangers

2.2.1 Electrical equipment / installations



There must not be any electrical cables and devices underneath or in the immediate vicinity of the filter!

Electrical devices / equipment that are not splash-water proof and are situated in the direct vicinity of the filter may be damaged by water leaking from the filter caused as a result of the device not being operated in accordance with the manufacturer's specifications. In the event of such cases persons are at risk and may sustain electrical shocks. Therefore any electrical devices / equipment situated in the direct vicinity should be splash-water proof, respectively comply with the statutory requirements for wet areas. Always check with local authorities prior to installations.

3. Product Information

3.1 Intended purpose

This filter is suitable for use in cold drinking water up to a maximum water temperature of 30 °C (86 °F).



(see chapter “Safety information and dangers due to non-compliance”)

Please refer to the chapter on “Intended Use” for use restrictions.

This filter removes coarse and fine-grained particles from the water which are larger than or equal in size to the mesh size of the filter.



Particles smaller than the supplied mesh size and impurities causing turbidity cannot be filtered out of the water.

3.2 Test mark

CSA

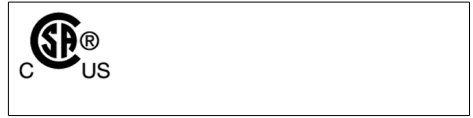

Fig. 2: Test mark

This domestic water station has been certified by CSA. As well as certified to NSF/ANSI B16.1 (see fig. 2).

3.3 Materials used

The materials used are resistant to the physical, chemical, and corrosive loads to be expected in the drinking water and fulfill the requirements specified in DIN EN 13443-1 and DIN 19628 (“Mechanical filters in drinking water installations”) and DIN EN 1567 (“water-related containment fittings - pressure reducers and pressure-reducer combinations”) / required standards.

All materials are hygienically and physiologically uncritical. Plastics fulfill the requirements of the CSA guidelines (CSA - Canadian Standards Association) and the DVGW work sheet W270. Metallic materials fulfill the requirements of DIN 50930-6 (Impact on the Drinking Water Quality).

4. Installation

4.1 General



(see chapter “Safety information and dangers due to non-compliance”)

The unit may only be installed by skilled personnel.

The chapter on “Intended Use” must always be observed!

The piping must be able to safely support this product.

Otherwise mechanical damage or fractures/bursts can occur in the pipes. This can result in major water damage and personal injury. Therefore, if necessary, the pipes must be additionally fixed or supported.

For convenient operation and maintenance it is absolutely necessary to ensure the given spacings (see chapter “Discharging the backwashing water”).

A space of at least 200 mm (8 ") should be maintained above and below the filter. These distances are necessary to be able to properly carry out the backwashing (see chapter “Backwashing”).

4.1.1 Requirements for the place of installation

The room where the unit is installed must be dry and frost free!

Unauthorized persons must not have access to the filter!



(see chapter “Safety information and dangers due to non-compliance”)

- The water temperature must not exceed 30 °C (86 °F)! At higher temperatures or direct sun radiation the material can be damaged and the filter housing may even break.
- In order to be able to safely discharge the wastewater in operation and in case of any defects that occur in the system, precise compliance with the details given in the “Installation” chapter is necessary! If the wastewater (backwashing) cannot be safely and completely discharged, water damage can occur.
- A shut-off valve must be installed upstream of the filter! This enables the water supply to the filter to be interrupted during installation, servicing/maintenance, repairs and in case of malfunctions. Floods and serious water damage can therefore be avoided.
- The unit can be installed in all standard drinking water pipes.
- It is not permitted to install the filter **upstream of** the water meter!



The shipping carton can be slipped over the built-in filter to prevent damage, for instance at construction sites.

4.1.2 Installation position



(see chapter “Safety information and dangers due to non-compliance”)

Always install the filter in a vertical position ($\pm 5^\circ$)!

Non-observance of this can cause uncontrolled leakage of backwashing water and can result in water damage.

4.1.3 Mounting the built-in rotary flanges

Install using the supplied built-in rotary flange. The built-in rotary flange is used as a connecting element between the pipe and the filter.

It is suitable for both horizontal and vertical pipes.

The built-in rotary flange must be installed in the direction of flow. This is marked by a cast in arrow (see fig. 4).

Failure to comply with this will result in the filter not working.



(see chapter “Safety information and dangers due to non-compliance”)

The flange surface of the built-in rotary flange must be in a horizontal position! The built-in rotary flange must be fitted so that mechanical stresses cannot occur! Otherwise mechanical damage can result in the built-in rotary flange and damage can result, the pipe may burst or the built-in rotary flange can break. This can result in major water damage and personal injury.

Therefore, during installation, ensure that no stress forces act on the pipe, built-in rotary flange and filter.

4.1.4 Installing the domestic water station

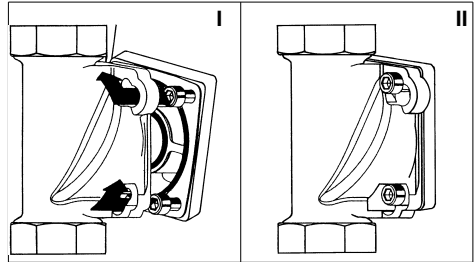

Fig. 3: Built-in rotary flange with bayonet fixture

The built-in rotary flange for the filter is supplied with bayonet drill holes. The necessary seals and screws for this filter have already been mounted.

Do not unscrew the screws!

- Insert the four flange screws in the bayonet drill holes on the built-in rotary flange (see fig. 3 I).
- Turn the filter in a clockwise direction as far as it will go (see fig. 3 II).
- Tighten the four flange screws.



Select the torque (approx. 4 Nm) so that the gasket closes and the filter is not damaged or strained!



ATTENTION

(see chapter “Safety information and dangers due to non-compliance”)

The section of the profiled flange gasket must point towards the built-in rotary flange. Failure to observe this can lead to leaks and water escaping. This can in turn cause water damage (see fig. 4).

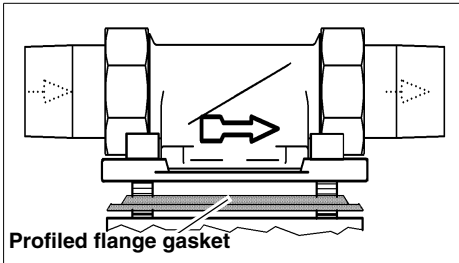

Fig. 4: Built-in rotary flange

4.2 Discharging backwash water



ATTENTION

(see chapter “Safety information and dangers due to non-compliance”)

An adequately dimensioned wastewater connection (e.g. floor drain) must be available for the backwashing water.

The dimensions depend on the local circumstances (e.g. wastewater pipe gradient, number of pipe bends, length of the wastewater pipe, etc.). The dimensioning must at least allow all the wastewater to be discharged at the same time. If it is not possible to provide a wastewater connection directly beneath the filter, the flushing water can be fed several meters to the next wastewater connection, either through a hose or a pipe to be fitted to the flushing water valve. This pipe must have the same dimension as the flushing water valve.

In all options, a free discharge must be ensured (air gap, air break).

The following points must be noted if a bucket is used for backwashing:

- If the water mains pressure is high, water can splash out of the bucket. In this case, damage to property close to the filter is possible.
- When the bucket is half-filled the backwashing process must be stopped. Otherwise it is possible for the bucket to overflow. Therefore the bucket must be adequately sized and the backwashing should be carried out quickly.

4.2.1 Backwashing water discharge options

JPM ¾" – 1¼"

JPM 1½" – 2"



Abb. 5: Backwashing water discharge options

5. Operation

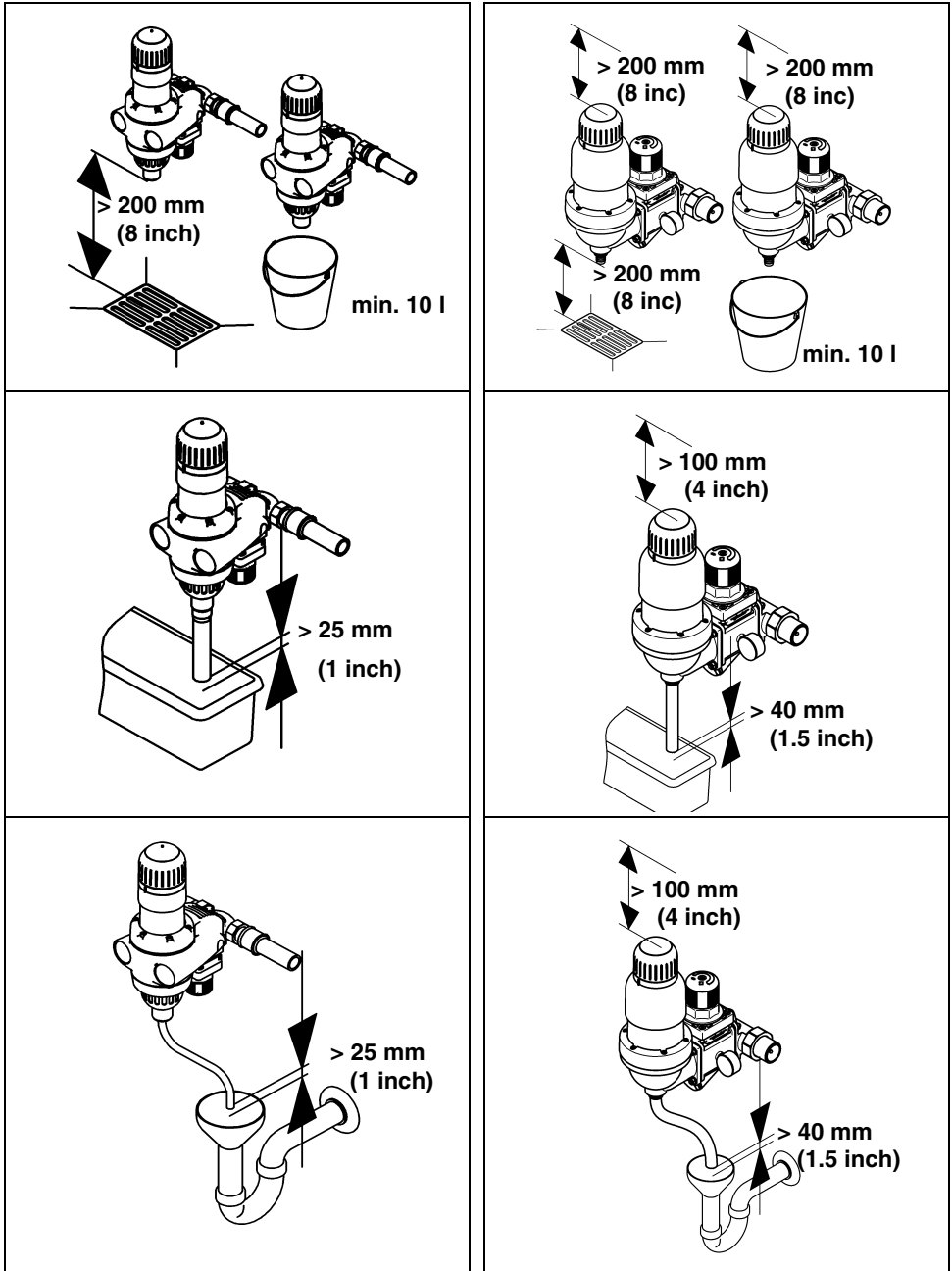

(see chapter “Safety information and dangers due to non-compliance”)

Imperatively observe the chapter “Intended use”!

5.1 Commissioning

Before starting up (initial putting into service or startup after maintenance work), **fill** the filter with water and **vent**!

- After installation, the filter is filled with water by opening the upstream shut-off valve.
- The filter is now at the same pressure as the water system.
- The enclosed air must then be immediately removed from the filter in order to avoid damage to the installation caused by pressure surges. The filter is vented by means of backwashing (see chapter “Discharging the backwashing water”).
- After backwashing and venting, the filter is ready for use.
- **Note electronics only JPM ¾" – 1¼"**: Memory electronics are found under the lid of the handwheel. It uses an acoustic alarm as a reminder, that every two months the filter needs to be backwashed, maximum backwash intervals.
Activation:
 - Lift the lid of the handwheel.
 - Insert the two batteries in the battery compartment. Use 1.5 V (AAA) batteries supplied.
 - Replace the handwheel lid.
 - You can test the functionality by pressing the RESET-key in the lid of the handwheel.

5.2 Pressure Setting

To change the factory-set pressure of 58 psi.

- Loosen countersunk screw on the hand-wheel of the pressure reducer.
- Turn the hand-wheel in a clockwise direction = pressure increase
- Turn the hand-wheel counter-clockwise = pressure reduction
- The pressure setting-range is recommended between 25 psi and 85 psi.
- Open a tap downstream of the PROMI as a pressure relief and the set pressure can be read.
- As soon as the desired setting-range is reached, re-tighten the countersunk screw on the hand-wheel of the pressure reducer.
- The fixing of the countersunk screw on the handwheel of the pressure reducer is recommended to lock in the setting.

5.3 Function Description

Unfiltered water runs through the built-in rotary flange (1) into the domestic water station.

The water runs through the backflow preventer and then through the fine filter. The filtered dirt will be trapped on the screen mesh of the fine filter. The adherent dirt is externally visible via the transparent filter housing (4). The filtered water continues to run into the pressure reducer (5). The set outlet-pressure can be read off on the outlet pressure gauge (7). Then the filtered water runs out of the domestic water station via the built-in rotary flange (1).

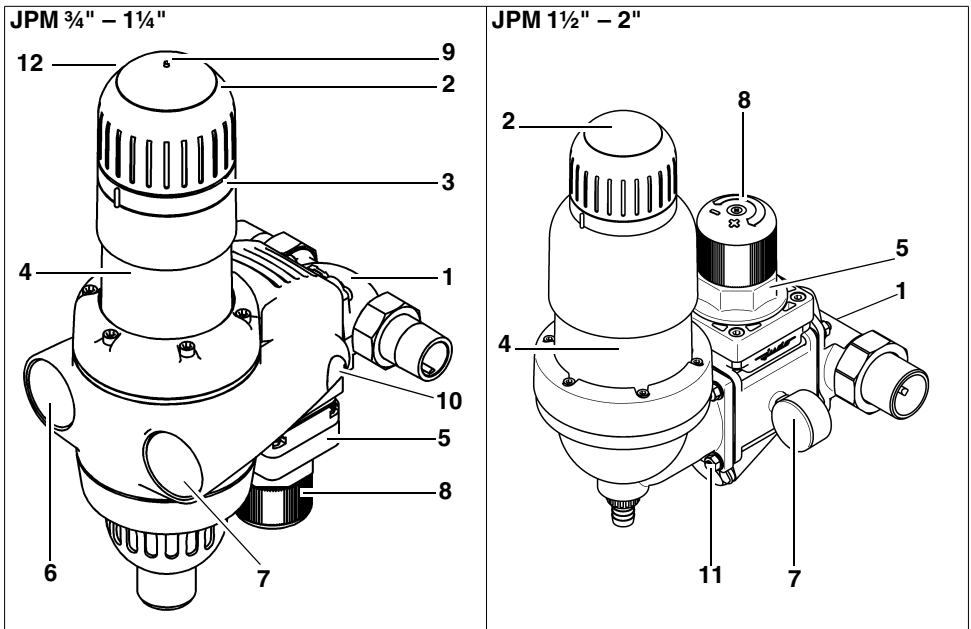

Fig. 6: Function description

- | | |
|---|---|
| <ul style="list-style-type: none"> 1 Built-in rotary flange 2 Hand-wheel to operate the backwash performance 3 Guide ring to perform the next backwash date 4 Filter housing 5 Pressure reducer 6 Inlet pressure gauge 7 Outlet pressure gauge | <ul style="list-style-type: none"> 8 Hand-wheel of the pressure reducer 9 RESET-BUTTON /MEMORY ELECTRONIC 10 Screw cover 11 Protection Cap – Backflow preventer 12 Memory Electronic and Battery box |
|---|---|

5.4 Backwashing

Physical impurities retained and trapped on the filter sieve are removed by backwashing. During the backwashing, there is no interruption to the water supply, nor any interruption to the filtration. The backwash waste water is diverted to the rinsing valve having no contact with the filtered water supply.

Backwashing is performed based on a patented point-rotation system.

A backwash is activated by turning the hand-wheel (2) counter-clockwise, this automatically opens the rinsing valve, continue to rotate the hand-wheel counter-clockwise until a stop position is reached. During this rotation you will notice that the suction pipe arms rotate around the filter sieve, in an upward direction following a spiral path, which will clean the entire filter area until the stop is reached. Once the stop position is reached the filter sieve has been cleaned once, but the backwash cycle is not completed. The backwash is complete by then turning the hand-wheel in a clockwise direction. During this rotation you will notice that the suction pipe arms rotate around the filter sieve, in a downward direction following the same spiral path, which will clean the entire filter area for a second time until the stop position is reached. Turning the hand-wheel in a clockwise position until the stop position is reached is essential in completing a backwash, as it closes the rinsing valve simultaneously.

Therefore:

Step 1 - turn hand-wheel (2) counter clockwise, until stop point to open rinsing valve.

Step 2 - turn hand-wheel (2) clockwise until stop point to close rinsing valve.

During a backwash, the suction control arms create a reverse flow action at each nozzle piece, resulting in a vacuum effect, which removes all trapped physical impurities using the inlet water pressure; ejecting them all to drain via the rinsing valve.

Each nozzle piece is equipped with wiper blades, during the upward and downward backwash rotations, these wiper blades clean the sight glass simultaneously.

Backwash intervals are subject to the water quality conditions and the amount of physical impurities. A backwash should be performed as often as required. Loss of water pressure is noticed if a backwash is not performed regularly or as often as required.

The hand-wheel (2) cover houses a memory control (JPM $\frac{3}{4}$ "-1 $\frac{1}{4}$ ") which issues an acoustic beep at two months intervals, as a reminder that a backwash is required. Pressing the reset button (9) on the top of the hand-wheel for a minimum of 3 seconds, deactivates the acoustic beep and resets the two months interval reminder.



The contamination degree as well as the cleaning operation can be externally observed.

5.4.1 Backwashing interval

The filter must be backwashed as often as required:

- Every six months at the latest.
- If there is a loss of pressure.
- If the backwash protective filter is visibly dirty.



(see chapter "Safety information and dangers due to non-compliance")

Unauthorized persons must not operate the filter! Persons who operate the filter must observe the operating instructions. Failure to observe these instructions can result in damage to property and personal injuries.

The smaller the mesh size of the sieve the more frequently backwashing has to be performed!

Experience shows that increased dirt is deposited during the initial running period. If so, the unit has to be flushed more often than usual.

Failure to backwash regularly can cause damage to the sieve. Larger quantities of filtered particles can deform the sieve and as an extreme incident can cause tearing of the sieve. As a result the filter function is no longer ensured. In addition, larger quantities of dirt can cause mechanical impairment concerning the backwashing function.

5.4.2 Note electronics (only for JPM ¾" – 1¼")

The note electronics in the handwheel reminds you to backwash every 2 months. You can also mark the next backwash date using the adjusting ring under the handwheel.

- Push the RESET-key to stop the beeping. This also restarts the 2-month time interval. Be sure to check batteries regularly to ensure they have not been exhausted. The beep is only considered an additional reminder for backwashing. Independent of that, the backwashing needs to be carried out every two months at the latest.

5.5 Modifications / changes / spare parts



ATTENTION



(see chapter "Safety information and dangers due to non-compliance")

Only original spare parts are to be used!

Arbitrary modifications and changes are prohibited for safety reasons! They can impair the function of the filter, lead to leaks and as an extreme incident they can lead to the bursting of the filter.

The imprinted test marks are only valid if original spare parts are used.

5.5.1 Servicing / Repair

Prior to servicing or repairing the PROMI. You must turn off the water supply valve, located upstream of the unit and depressurize the filter.

Failure to observe this can lead to property damage and personal injury.

Strict compliance with the instructions given in the "Installation" and "Maintenance" chapters is required.

5.5.2 Backflow Preventer Testing

JPM ¾" - 1¼"

The hollow-bolt of the inlet-pressure gauge (0 - 232 psi). Serves as a control-screw to test the function of the backflow preventer

Remove the lateral screw cover and unscrew the control-screw by means of an Allen key.

Attention: When screwing-in the hollow-bolt. It has to be straightly -positioned and screwed in, to avoid damage to the plastic threads.

JPM 1½" - 2"

The inlet-pressure gauge serves as a control-screw to test the fuction of the back-flow-preventer. To replace the backflow preventer, the lower cap (11) has to be unscrewed and screwed in again after replacement has been made.

5.6 Stoppages



ATTENTION



(see chapter "Safety information and dangers due to non-compliance")

If a filter has to be removed from the flange or unscrewed, the chapter "Intended use" has to be observed!

- Protect the flange surfaces from damage! Damaged flange surfaces cannot close tight any longer. As a result, escaping water can damage the building and installations.
- Store the filter in frost-free conditions! The water contained in the filter can freeze due to frost and thus the filter can be mechanically damaged to a degree that it will become untight at operating pressure or it can burst. Leaking water can cause major material-damages to the building and personal injury can occur.
- When recommissioning the filter, strictly comply with the instructions given in this manual.

6. Faults

The opening of the unit and the replacement of the water pressure charged parts may only be effected by authorized personnel in order to ensure the unit security and its tightness.

Help with faults:

Trouble	Cause	Solution
Backwashing water continues running!	Flushing valve not fully closed.	Repeat the backwashing and then turn the handwheel until it locks into place!
	Dirt in the flushing valve.	
Lack of water pressure!	Screen is blocked.	Carry out backwashing
Leaks in the backwash protective filter!	Filter has been subjected to high temperatures or has been in contact with solvents.	Inform the fitter or nearest customer service centre. (The filter cover must be replaced immediately.)
Filter cover becomes turbid!		
Hairline cracks on the filter hood!		
When a zero flow condition exists, the outlet pressure increases slowly!	Unallowable pressure increase through utility water temperature rise.	Control of the safety valve of the hot water boiler. Contact plumber or the nearest customer service.
	Wear of the pressure reducer cartridge.	
Note electronics beeps! (JPM ¾" – 1¼")	Backwashing is due.	Carry out backwashing. Keep the RESET-key pressed for at least 3 seconds.
The note electronics does not beep when the reset-key is pressed! (JPM ¾" – 1¼")	The battery is used up.	Replace the batteries with new ones. Return used batteries to the collection centres.

7. Maintenance



ATTENTION

(see chapter "Safety information and dangers due to non-compliance")

Always observe the chapter "Units used"!

7.1 Cleaning



ATTENTION

(see chapter "Safety information and dangers due to non-compliance")

Use only clear, drinking water concerning the cleaning of the filter and the transparent filter housing.

Domestic all-purpose cleaners and glass cleaners can contain up to 25 % solvents or alcohol (spirits).

These substances can chemically attack the plastic parts, which can weaken the plastic parts causing fractures and breaks.

These kinds of cleaners must therefore be avoided.

7.2 Checking the note electronics (only JPM ¾" – 1¼")

Check the note electronics as follows:

- Press the RESET-key for at least 3 seconds.

If a beep sounds, the note electronics are functioning and the batteries still have sufficient capacity. This battery test does not have any influence on the two-month interval.

If no beep sounds, the batteries have to be replaced with fresh batteries.

Replacing the batteries:

- Lift the lid of the handwheel.
- Replace the batteries located in the battery compartment with new, identical batteries (size AAA).
- Replace the handwheel lid.
- Press the RESET-key in the lid of the handwheel for at least 3 seconds. The two-month time interval is restarted.
- Used batteries are to be returned to a distributor or to one of the returning facilities established to this purpose by the public recycling entities.



(see chapter "Safety information and dangers due to non-compliance")

To make sure the total interval of two-months is not exceeded, backwash the filter after replacing the batteries.

7.3 Filter sieve

The filter sieve:

The unit includes a filter sieve with a stainless steel screen mesh.

8. Warranty and Services

In order to comply with the legal warranty claim, it is necessary that backwashing takes place according to the existing operating conditions (see chapter 5.4.1).

DIN EN 13441-1 specifies that backwashing must take place at least every six months.

However, JUDO recommends to carry out backwashing every two months!

Further, an annual check of the set discharge pressure at the pressure gauge (visual check) when no water is flowing and at the peak flow (large amount drawn off) is necessary.

Regular inspection and routine servicing are indispensable in order to continue to achieve a successful process for many years after the unit is put into service. In the domestic engineering field this is covered by DIN EN 806-5.

A servicing agreement is the best way to ensure a good operating function beyond the warranty period.

Wherever possible, the regular servicing work and supply with consumables and wearing materials, etc. should be carried out by the specialist trade or the factory's customer service department.

9. Data Sheet

9.1 Type

JUDO PROMI
Domestic water station
Abbreviated name: JPM

9.2 Models

Models	Order no.
JPM ¾"	8150120
JPM 1"	8150121
JPM 1¼"	8150122
JPM 1½"	8150123
JPM 2"	8150124

9.3 Technical Data

The following applies for all the models of this device:

- Pressure loss when clean (after backwashing): 3 psi (20 kPa) at the water flow rate (nominal flow rate) given in the table.
- Maximum ambient temperature and water temperature: 30 °C (86 °F).
- **The water to be filtered must possess quality of drinking water!**

Nominal Pressure

Models	Operating pressure	Nominal pressure
JPM ¾" – 2"	22 - 150 psi (150 - 1000 kPa)	232 psi

The nominal pressure denotes the pressure class, according to which the filter must fulfil the requirements to DIN EN 13443-1 and DIN 19628. The maximum operating pressure is lower, in order to ensure the optimum function of the filter

Weight

Models	Weight
JPM ¾"	4.9 kg
JPM 1"	5.2 kg
JPM 1¼"	5.6 kg
JPM 1½"	17.5 kg
JPM 2"	18.7 kg

Water Flow Rate

Models	Water flow rate with a clean sieve insert ¹⁾
JPM ¾"	10.1 gpm
JPM 1"	15.8 gpm
JPM 1¼"	25.5 gpm
JPM 1½"	40 gpm
JPM 2"	61.6 gpm

- 1) Data concerning the water flow rate are valid for drinking water. The maximum water flow rate for more polluted water is lower, depending on the mesh size. If so, a larger dimension has to be chosen.

Back-flush volume stream

Models	Back-flush volume stream
JPM ¾"	0.3 l/s (5 gpm)
JPM 1"	0.3 - 0.8 l/s (5 - 13 gpm)
JPM 1¼"	0.3 - 0.8 l/s (5 - 13 gpm)
JPM 1½"	0.3 - 0.8 l/s (5 - 13 gpm)
JPM 2"	0.3 - 0.8 l/s (5 - 13 gpm)

The backwashing volumetric flow given applies to 30 - 60 psi mains pressure and for a completely opened flushing water valve.

9.4 Installing dimensions JPM 3/4" - 1 1/4"

Models	A	B	C	D	E	F	G
JPM 3/4"	7	6.9	11	6.4	8.9	6.3	1.5
JPM 1"	7.6	6.9	11	6.4	8.9	6.3	1.5
JPM 1 1/4"	9	6.9	11	6.4	9.1	6.5	1.5

All dimensions in (inch)
(see Fig. 7 and Fig. 8)

A = Installation length

B = Unit width

C = Height above pipe centre

D = Height below pipe centre

E = Depth to pipe centre

F = Waste water connection centre
to pipe centre

G = Connection dimension waste water

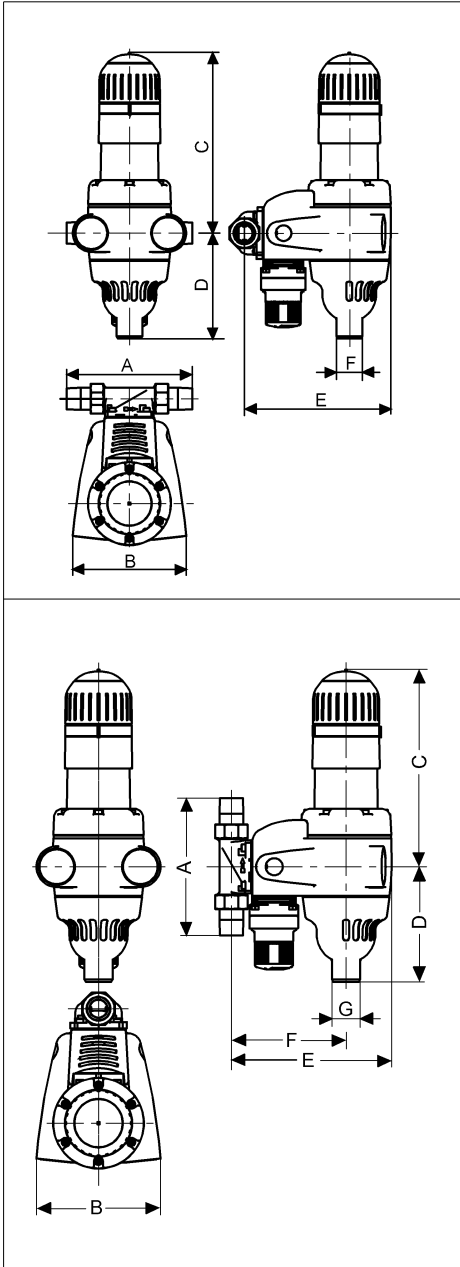

Fig. 7: Installing dimensions JPM 3/4" - 1 1/4"

9.5 Installing dimensions JPM 1½" - 2"

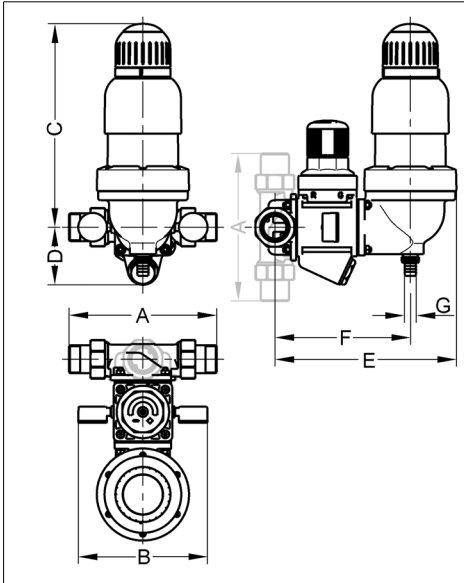

Fig. 8: Installing dimensions JPM 1½" - 2"

Models	A	B	C	D	E	F	G
JPM 1½"	9.9	8.6	13.7	3.9	12.2	9.1	0.8
JPM 2"	11	8.6	13.7	3.9	12.5	9.4	0.8

All dimensions in (inch)
(see Fig. 7 and Fig. 8)

A = Installation length

B = Unit width

C = Height above pipe centre

D = Height below pipe centre

E = Depth to pipe centre

F = Waste water connection centre to pipe centre

G = Connection dimension waste water

9.6 Extent of Supply

- Completely pre-assembled domestic water station
- Installation- and operation instructions

JPM ¾" – 1¼":

- 1 x built-in rotary flange JQE ¾", 1" or 1¼" with bayonet-type connection and screw connection,
- 2 x batteries to be used in the Memory Electronic (size AAA).

10. Spare Parts

10.1 JPM 3/4" - 1 1/4"

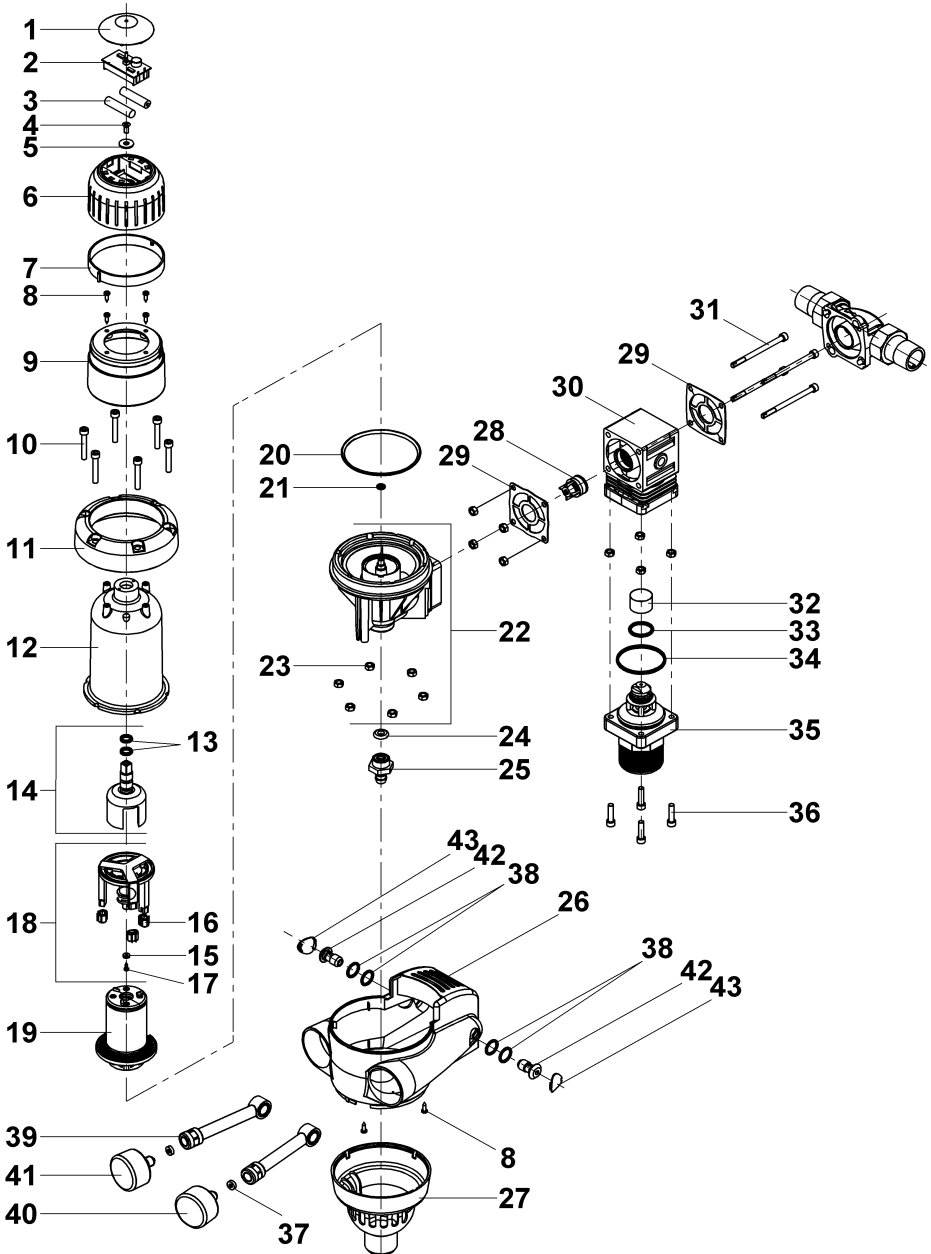

List of Spare Parts JPM ¾" – 1¼"

Item	Designation (Recommended average replacement interval for wearing parts[*])	Piece(s)	Order No.
	Wearing parts set "Pressure reducer cartridge" (consisting of pos. 33, 34, 35) ****	1	2150026
	Wearing parts set "Sieve 0.1 mm, suction pipe and gaskets" (consisting of pos. 18, 19, 20, 21) ***	1	2020819
	Wearing parts set "Gaskets" (consisting of pos. 13, 15, 16, 17, 20, 21, 24, 29, 37, 38) ****	1	2010335
	Spare parts kit "Note electronics" (consisting of pos. 1, 2, 3)	1	2010516
	Spare parts kit "Manometer 0 - 232 psi" (consisting of pos. 37, 41)	1	2170120
	Spare parts kit "Manometer 0 - 145 psi" (consisting of pos. 37, 40)	1	2170121
1	Lid of handwheel	1	
2	Note electronics	1	
3	Battery 1.5 V Type AAA	2	
4	Countersunk screw M5x12	1	1607454
5	Washer A 6.4	1	1650142
6	Memo handwheel	1	1120431
7	Adjusting ring	1	1120680
8	Self-tapping screw 3.5x13	6	1607114
9	Upper housing part	1	2010383
	Type plate	1	1701915
10	Cylinder Screw M6x40	6	1650123
11	Flange ring	1	2010382
12	Filter housing	1	2010424
13	O-ring 10x3	2	
14	Carrier	1	2010146
15	Suction Pipe Gasket	1	
16	Mouthpiece (Nozzle)	3	
17	Plate Screw 2.9x9,5	1	
18	Suction pipe complete	1	

List of Spare Parts JPM ¾" – 1¼"

Item	Designation (Recommended average replacement interval for wearing parts[*])	Piece(s)	Order No.
19	Filter Screen MW 0.10 mm (0.004 inch)	1	
20	O-ring 90x4	1	
21	O-ring 6.5x2	1	
22	Filter Bottom Piece	1	2020152
23	Hexagonal nut M6	10	1633145
24	O-ring 6.5x6	1	
25	Tube Connection	1	1120310
26	Upper Housing Part	1	2160106
27	Filter Funnel	1	1120298
28	Backflow preventer	1	1610311
29	Profile flange seal	2	
30	Safety block	1	2100057
31	Cylinder Screw M6x88	4	2010198
32	Noise screen	1	1400071
33	O-ring 25x3.5	1	
34	O-ring 52x3.5	1	
35	Cartridge	1	
36	Cylinder Screw M6x25	4	1633140
37	Manometer seal	2	
38	O-ring 14.5x2.5	4	
39	Pressure gauge tube	2	1120349
40	Manometer 0-145 psi (Subsequent Pressure)	1	
41	Manometer 0-232 psi (Primary Pressure)	1	
42	Hollow screw	2	1650217
43	Screwing cover	2	1120679

Replacement interval:

*** = 3 years

**** = 4 years

10.2 JPM 1½" - 2"

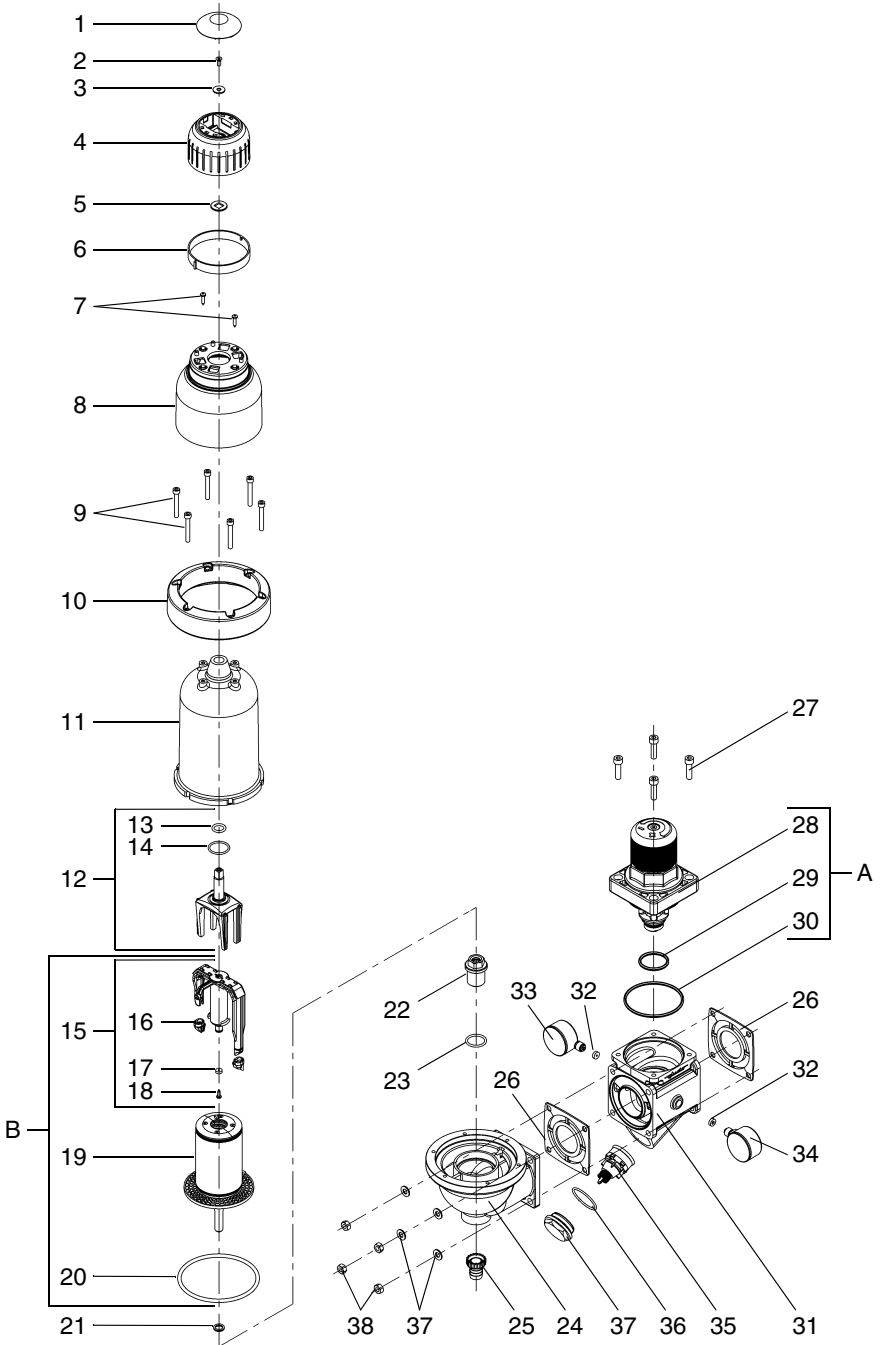

List of Spare Parts JPM 1½" – 2"

Pos.	Designation (Recommended average replacement interval for wearing parts [*)	Piece(s)	Order No.
A	Wearing parts set "Pressure reducer cartridge" (consisting of pos. 28, 29, 30) ****	1	2170567
B	Wearing parts set "Sieve 0.1 mm, suction pipe and gaskets" (consisting of pos. 13, 14, 15, 19, 20, 21) ****	1	2020821
	Wearing parts set "Gaskets" (consisting of pos. 13, 14, 16, 17, 18, 20, 21, 26) ***	1	2010337
	Spare parts kit "Handweel" (consisting of pos. 1, 2, 3, 4, 6)	1	2020994
	Spare parts kit "Manometer 0 - 232 psi" (consisting of pos. 32, 33)	1	2100003
	Spare parts kit "Manometer 0 - 145 psi" (consisting of pos. 32, 34)	1	2100002
1	Lid of handwheel	1	
2	Countersunk screw M5x12	1	
3	Washer A 6.4	1	
4	Handwheel	1	
5	Spacer disc	1	1120137
6	Adjusting ring	1	
7	Sheet-metal screw 4,2x19	2	1650393
8	Upper housing part	1	1120929
	Type plate	1	1701778
9	Cylinder screw M6x45	6	1607417
10	Flange ring	1	2020102
11	Filter housing	1	2010422
12	Carrier	1	2020034
13	O-Ring 15x3,2	1	
14	O-Ring 28x2,5	1	
15	Suction pipe complete	1	
16	Mouthpiece (Nozzle)	2	
17	Suction Pipe Gasket	1	
18	Plate Screw C3,5x13	1	

List of Spare Parts JPM 1½" – 2"

Pos.	Designation (Recommended average replacement interval for wearing parts [**])	Piece(s)	Order No.
19	Filter Screen MW 0.10 mm (0.004 inch)	1	
20	O-Ring 113,67x5,33	1	
21	O-Ring 12x3	1	
22	Connection Piece	1	1607154
23	O-Ring 26x3	1	1607111
24	Filter Bottom Piece	1	2607102
25	Hose coupling	1	1607157
26	Profile flange seal	1	
27	Cylinder Screw M8x30	4	1607116
28	Pressure reducer cartridge	1	
29	O-Ring 38x4	1	
30	O-Ring 84x4	1	
31	Safety block	1	1430069
32	Manometer seal	2	
33	Manometer 0-232 psi (Primary Pressure)	1	
34	Manometer 0-145 psi (Subsequent Pressure)	1	
35	Backflow preventer	1	1610318
36	O-Ring 42x2,7	1	1200143
37	Protection cap	1	1440082
38	Washer A 8,4	4	1607125
39	Hexagonal nut M8	4	1607117

Replacement interval:

*** = 3 years

**** = 4 years

11. Customer Service



JUDO Water Treatment Inc.

240 Lesmill Road
Toronto, ON M3B 2T5
Canada

Telephone: (416) 441-1556

Toll-free (Canada/USA): (866) 451-5836

Fax: (416) 391-4273

Toll-free fax (Canada/USA): (877) 761-3335

e-mail: info@judo-online.com

judo-online.com

Installed by:

All illustrations, dimensions and information for the different models are those valid on the date of printing. All rights are reserved for modifications as a result of technical progress or further developments. Claims with regard to models or products are excluded.

1701916 • 2014/10