

# Installation and Operating Instructions JUDO HEIFI-TOP

Backwash filter with venting system  $\frac{3}{4}$ " – 2"

Valid for: EU countries and Switzerland

Language: English

---

**Attention:**

Carefully read through the installation and operating instructions and safety information before installing and putting the unit into service.

These must always be issued to the owner/user.

---

**Extended warranty period if a service agreement is concluded!**

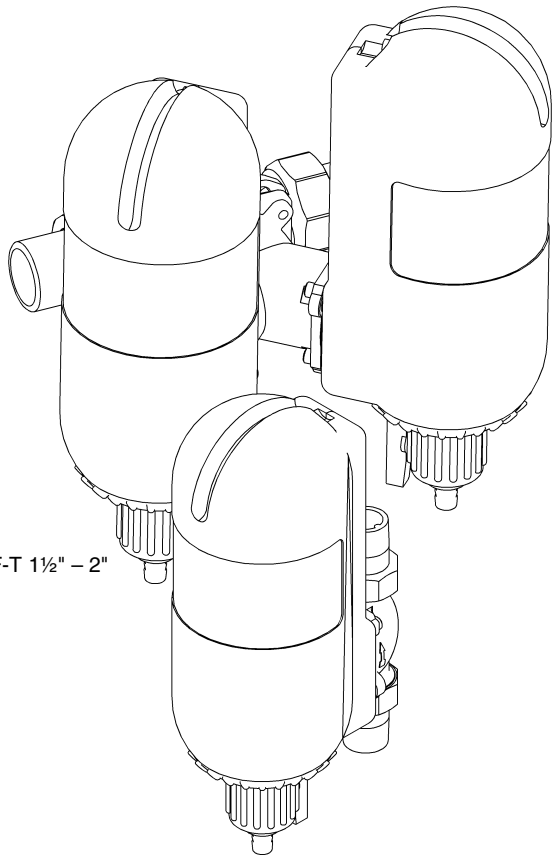

Fig.: JHF-T 1 1/2" – 2"

Fig.: JHF-T  $\frac{3}{4}$ " – 1 1/4"



## **Quiries, orders, customer support**

JUDO Wasseraufbereitung GmbH  
P.O. Box 380  
D-71351 Winnenden

Phone: +49 (0)7195/6 92-0  
Telefax: +49 (0)7195/6 92-188  
internet: <http://www.judo-online.de>  
e-mail: [info@judo-online.de](mailto:info@judo-online.de)

## **Address**

JUDO Wasseraufbereitung GmbH  
Hohreuschstrasse 39-41  
D-71364 Winnenden

**Dear Customer,**

**We would like to thank you for your confidence in us, which you have shown by purchasing this device. The product you have purchased is a filter developed using state of the art technology.**

**The backwash filter with venting system is used in heating circuits to filter and degassify the water. It removes coarse and fine-grained contaminations (e.g. rust silt), which can result in malfunctions in the controls. The backwash filter and venting system also removes undissolved, disruptive or corrosive gases (e.g. nitrogen and oxygen).**

**Each unit is thoroughly checked before delivery. Should difficulties nevertheless occur, please contact the responsible customer service. See back page.**

Trademarks:

Trademarks used in this document are protected and registered trademarks of the respective holder.

© JUDO Wasseraufbereitung GmbH  
D-71351 Winnenden

All rights reserved.  
Reprints – even of extracts – is only permitted with special approval.

**Table of Contents**

**1. About this Instruction Manual..... 3**

    1.1 Symbols used ..... 4

    1.2 Safety information and dangers due to non-compliance ..... 4

    1.3 Units used..... 4

**2. Intended Use ..... 5**

    2.1 Water Pressure..... 5

    2.2 Notes on special dangers ..... 5

**3. Product Information ..... 6**

    3.1 Intended purpose..... 6

**4. Installation ..... 6**

    4.1 General..... 6

    4.2 Discharging the backwashing water ..... 9

    4.3 Backwashing process..... 9

**5. Operation ..... 11**

    5.1 Commissioning ..... 11

    5.2 Functional description..... 11

    5.3 Backwashing ..... 12

    5.4 Backwashing interval..... 12

    5.5 Modifications / changes / spare parts..... 12

    5.6 Stoppages ..... 12

**6. Faults ..... 13**

**7. Maintenance..... 14**

    7.1 Cleaning ..... 14

**8. Warranty and Services..... 14**

**9. Data Sheet..... 15**

    9.1 Type..... 15

    9.2 Models ..... 15

    9.3 Technical Data..... 15

    9.4 Installed dimensions ¾" - 1¼" .. 16

    9.5 Installed dimensions 1½" - 2" .. 17

    9.6 Extent of Supply ..... 17

    9.7 Accessories JHF-T ¾" – 2" ..... 17

**10. Spare Parts ..... 18**

**11. Customer Service..... 20**

**Enclosure: Consultation Voucher**

**1. About this Instruction Manual**



(see chapter “Safety information and dangers due to non-compliance”)

The instruction manual must be permanently available at the place in which the filter is used.

This instruction manual is intended to make it easier to familiarize yourself with the filter and its possible intended uses.

The instruction manual contains important information in order to safely, properly and economically run the filter.

It contains fundamental information, which must be observed during installation, operation and maintenance. Observance of this information helps to avoid dangers, reduce repair costs and increase the reliability and service life of the filter.

The instruction manual must be read and used by each person entrusted with carrying out work on the filter, for example:

- **Installation**
- **Operation**
- **Maintenance** (servicing, inspection, repair)

Installation and maintenance may only be carried out by personnel authorized by the manufacturer, who are capable of fulfilling the instructions given in the installation and operating instructions and the country-specific regulations.

Apart from the instruction manual and the legally binding accident prevention provisions applicable in the country and place of use, the recognized technical regulations for safe and proper work must also be observed.

Therefore, this instruction manual must always be read by the fitter and responsible skilled personnel/owner or operator before

installation, putting into service and maintenance.

**Not only the general safety notes given in the chapter on “Intended Use” are to be observed, but also the special safety notes inserted under the other main items.**

### 1.1 Symbols used

The safety notes contained in this instruction manual are labelled with the following symbols:



Notes on existing dangers



Warning, electrical voltage.



Torques specified by the manufacturer.



Tips for use and other information.

Notes directly attached to the filter, e.g.

- Direction of flow (see Fig. 1)
- Rating plate
- Cleaning information

must always be observed and kept in a fully legible condition.

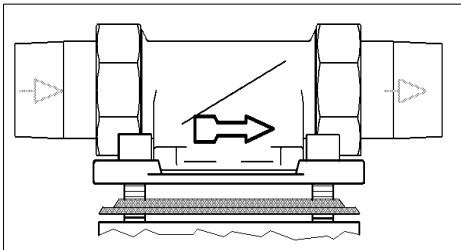

Fig. 1: Built-in rotary flange

### 1.2 Safety information and dangers due to non-compliance

In detail, failure to observe the general danger symbols can result, for example, in the following risks:

- Failure of important functions of the filter.
- Danger to persons due to electrical and mechanical effects.
- Danger to persons and the environment due to leaks.

Refrain from any unsafe working methods.

Failure to comply with this instruction manual and the safety information can not only result in dangers for people but can also harm the environment and the unit.

### 1.3 Units used

In derogation of the International System of Units (SI = System International), the following units are used:

Units	Conversion
°F	°F = 9/5°C + 32
bar	1 bar = 10 <sup>5</sup> Pa = 0,1 N/mm <sup>2</sup>
¾"	DN 20
1"	DN 25
1¼"	DN 32
1½"	DN 40
2"	DN 50

## 2. Intended Use

The installation and operation of the filter is subject to the following existing national regulations.

In addition to the operating instructions and the obliging regulations concerning accident prevention that exist in the country of operation and the location of use, the established technical regulations concerning safe and professional work, should also be observed.

The filter has been developed and manufactured using state of the art technology and the established safety regulations in Germany.

The filter may only be operated in accordance with the manufacturer's specifications. Any other operation or operation beyond the specified use, is not in accordance with the manufacturer's specifications.

Additional dangers may result in the event of the device not being operated in accordance with the manufacturer's specifications and non-observance of the danger symbols or safety instructions. The manufacturer / supplier cannot be made liable for any damages caused by these additional dangers. The operator is responsible for these risks.

The use of the device in accordance with the customer's specifications includes the observance of the operating instructions.

The manufacturer / supplier should be consulted prior to any operation of the filter other than in the operational areas stated in these operating instructions.

The filter may only be operated in a technically faultless condition, in accordance with the manufacturer's specifications and the stated safety and danger relevant instructions and under observance of the operating instructions!

**Any functional defects are to be removed immediately!**

## 2.1 Water Pressure

The water pressure must not exceed 1 bar as otherwise the backwashing can be impaired! If the filter is not backwashed regularly a pressure loss can result and this can impair the filter function.

## 2.2 Notes on special dangers

### 2.2.1 Electrical equipment / installations



There must not be any electrical cables and devices underneath or in the immediate vicinity of the filter!!

Electrical devices / equipment that are not splash-water proof and are situated in the direct vicinity of the filter may be damaged by water leaking from the filter caused as a result of the device not being operated in accordance with the manufacturer's specifications.

In addition this may also result short circuits if these electrical devices / equipment being connected to the electrical power supply. In the event of such cases persons are at risk and may sustain electrical shocks. Therefore any electrical devices / equipment situated in the direct vicinity should be splash-water proof, respectively comply with the statutory requirements for wet areas (IP44).

### 3. Product Information

#### 3.1 Intended purpose

The filter is suitable for use in heating circuits up to a hot water temperature of max 90°C.

It is not possible to install it in drinking water pipes!

### 4. Installation

#### 4.1 General



(see chapter “Safety information and dangers due to non-compliance”)

The unit may only be installed by skilled personnel.

The chapter on “Intended Use” must always be observed!

The pipes must be able to safely support the filter.

Otherwise mechanical damage or fractures/bursts can occur in the pipes. This can result in major water damage. People close to the filter are exposed to a health risk due to the large quantities of water released. Therefore, if necessary, the pipes must be additionally fixed or supported.

A space of at least 250mm should be maintained above and below the filter. These distances are necessary to be able to properly carry out the backwashing (see chapter “Backwashing”).

### 4.1.1 Requirements for the place of installation

**The room where the unit is installed must be dry and frost free!**

**Unauthorised persons must not have access to the filter!**



(see chapter “Safety information and dangers due to non-compliance”)

- In order to be able to safely discharge the wastewater in operation and in case of any defects that occur in the system, precise compliance with the details given in the “Installation” chapter is necessary! If the wastewater (backwashing) cannot be safely and completely discharged, the house and installations can be damaged by water.
- A shut-off valve must be installed upstream and downstream of the filter ! This enables the water supply to the filter to be interrupted during installation, servicing/maintenance, repairs and in case of malfunctions. Floods and serious water damage to house installations can therefore be avoided.

### 4.1.2 Installed position



(see chapter “Safety information and dangers due to non-compliance”)

Always install the filter in a vertical position ( $\pm 5^\circ$ )!

### 4.1.3 Mounting the built-in rotary flanges

Install using the supplied built-in rotary flange. The built-in rotary flange is used as a connecting element between the pipe and the filter.

The built-in rotary flange is suitable both for horizontal and vertical pipes.

It is suitable for both horizontal and vertical pipes.

**The built-in rotary flange must be installed in the direction of flow. This is marked by a cast in arrow.**

Failure to comply with this means the filter cannot work.

It must be ensured that no backflow preventer, gravity brake or any other automatic shut-off device is installed between the filter and the expansion vessel.

If this is not observed, backwashing is not possible as no backwashing water is available.



(see chapter “Safety information and dangers due to non-compliance”)

The flange surface of the built-in rotary flange must be in a vertical position! The built-in rotary flange must be fitted so that mechanical stresses cannot occur! Otherwise mechanical damage can result in the built-in rotary flange. Otherwise mechanical damage can result, the pipe may burst or the built-in rotary flange can break. This can result in major water damage.

In this case, people close to the filter are exposed to a health risk due to the large quantities of water.

Therefore, during installation, ensure that no large forces act on the pipe, built-in rotary flange and filter.

#### 4.1.4 Installing the filter

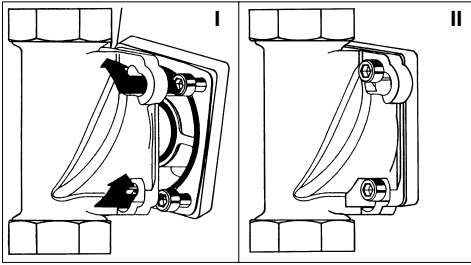

Fig. 2: Built-in rotary flange with Bayonet Fixture

The built-in rotary flange for the filter is supplied with bayonet drill holes. The necessary seals and screws for this filter have already been mounted.

#### Do not unscrew the screws!

- insert the four flange screws in the bayonet drill holes on the built-in rotary flange (see Fig. 3I).
- turn the filter in a clockwise direction as far as it will go (see Fig. 3II).
- Tighten the four flange screws.



Select the torque (approx. 4 Nm) so that the gasket closes and the filter is not damaged or strained!



(see chapter “Safety information and dangers due to non-compliance”)

The section of the profiled flange gasket must point towards the built-in rotary flange. Failure to observe this can lead to leaks and water escaping. This can in turn cause water damage to the house and its installations (see Fig. 3).

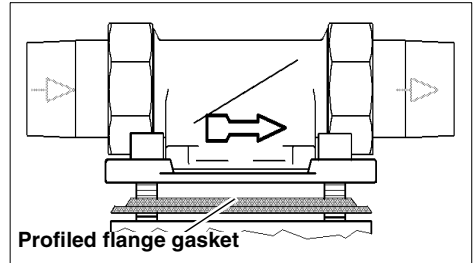

Fig. 3: Built-in rotary flange



## 4.2 Discharging the backwashing water



(see chapter “Safety information and dangers due to non-compliance”)

An adequately dimensioned wastewater connection (e.g. floor drain) to DIN 1986 must be available for the backwashing water. If there is no wastewater connection an appropriately sized bucket can be used.

## 4.3 Backwashing process



(see chapter “Safety information and dangers due to non-compliance”)

During the backwashing process hot water is discharged at the wastewater sockets – **careful - risk of scalding!**

If retrospectively installed in the heating system, the filter should be backwashed every 14 days until the backwashing water is clear. After this it suffices to backwash the system at the start and end of each heating period.

For backwashing the handwheel must be turned to the left up until the limit stop. This makes the integrated ball valve handle accessible from the front. By opening the ball valve the filter is backwashed (see chapter “Backwashing”).

### Caution – risk of scalding!

After approx. 2 to 3 litres of backwashing water has been flushed through the ball valve must be tightly closed again. Turn the handwheel back to the right up to the limit stop. This places the filter back in the operating position. The ball valve handle is now at the back of the filter again.

The heating water circuit must be returned to operating pressure by topping it up through the infeed point, unless a filling station has been installed. The expansion ves-

sel inlet pressure and the operating pressure must be set before the filter is put into service. They must be checked and set at least once a year.

The following points must be observed if a bucket is used for the backwashing:

- If the pressure is high water can splash out of the bucket and the end of the hose can fall out of the bucket. **Caution – risk of scalding!** In this case objects near the filter can be damaged.
- When the bucket is half full the backwashing process must be ended. Otherwise the bucket can overflow. Therefore the bucket must be adequately dimensioned (see Fig. 4).

### 4.3.1 Backwashing water discharge options

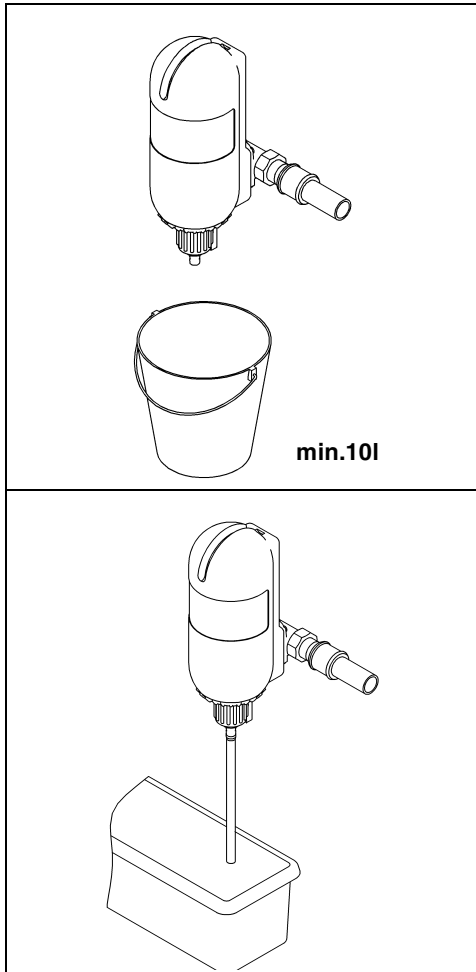

Fig. 4: Backwashing water discharge options

## 5. Operation



(see chapter “Safety information and dangers due to non-compliance”)

Always observe the chapter on “Intended Use”!

### 5.1 Commissioning

Before starting up (initial putting into service or startup after maintenance work), **fill the filter with water and vent!**

- To do this, after installation the filter is brought to operating pressure by filling it at the infeed point of the heating water circuit.
- The filter is now under water pressure.
- The enclosed air is removed from the filter through the venting system. It is advisable to carry out a trial backwash after venting (see chapter “Discharging the backwashing water”).
- After backwashing and venting the filter is ready for use.

### 5.2 Functional description

The heating water (**a**) flows through the built-in rotary flange (**1**) into the filter. This flushes the round filter brush (**2**) from below upwards. The dirt particles in the heating water (**a**) settle on the round filter brushes (**2**). Gas bubbles form in the heating water (**a**), which are collected by the round filter brushes (**2**) and are passed into the upper housing chamber (**3**). The heating water is degassed by a rapid venter (**4**) and the filtered and degassed heating water (**b**) thus returns to the heating circuit.

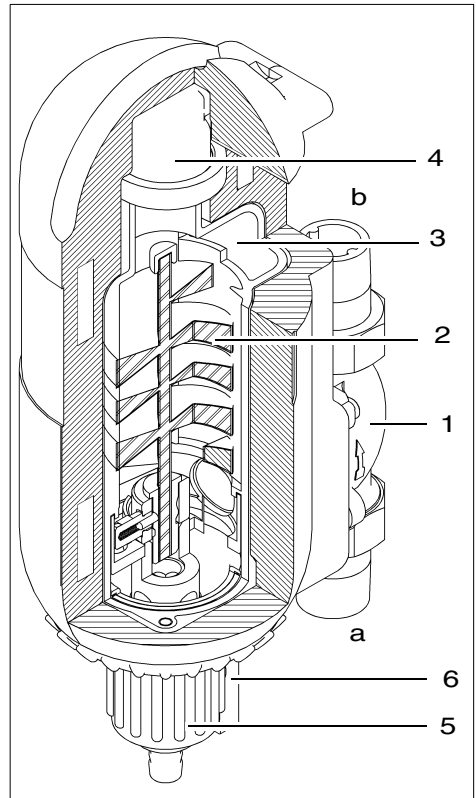

Fig. 5: Functional description

- 1 Built-in rotary flange
- 2 Round filter brush
- 3 Housing chamber
- 4 Rapid venter
- 5 Handwheel
- 6 Ball valve handle
- a Heating water inlet
- b Filtered water

### 5.3 Backwashing

The filter must be backwashed (cleaned) at the prescribed intervals in order to remove the dirt particles (see chapter “Backwashing process”).



(see chapter “Safety information and dangers due to non-compliance”)

In the operating position the ball valve handle (6) on the handwheel (5) is at the back of the filter. The handwheel (5) must be turned to the left up to the limit stop for backwashing, so that the integrated ball valve handle (6) is accessible from the front. During this turning movement the inlet valve is closed internally and the dirt particles are brushed by the round filter brush (2).

The filter is backwashed by opening the ball valve.

#### Caution – risk of scalding!

During the backwashing the heating water flows from the top downwards (reversed flow) through the round filter brush (2), this flushes the dirt particles downwards through the open ball valve. After approx. 2 to 3 litres of backwashing water have been flushed through the ball valve must be closed again tightly. Turn the handwheel (5) back to the right up to the limit stop. The filter is now in the operating position. The ball valve handle (6) is now back behind the filter (see Fig. 5).

### 5.4 Backwashing interval

If the filter is installed retrospectively in old heating systems the backwashing should be carried out every 14 days until the backwashing water clears. After that it suffices to carry out the backwashing as for a new heating system, i.e. at the start and end of each heating period.

### 5.5 Modifications / changes / spare parts

Before working on the filter extending beyond pure operational controls, the filter must be depressurised and left to cool!

#### 5.5.1 Servicing / Repair

Before working on the backwash filter extending beyond pure operational controls, the backwash filter must be depressurised and left to cool! Failure to observe this can lead to an uncontrolled escape of water and therefore lead to water damage in the building. Strictly comply with the instructions given in the “Installation” and “Maintenance” chapters.

### 5.6 Stoppages



(see chapter “Safety information and dangers due to non-compliance”)

If a filter has to be removed from the flange or unscrewed, the chapter “Intended use” must always be observed!

- Protect the flange surfaces from damage! Damaged flanged surfaces cannot close tight. As a result, escaping water can damage the building and installations.
- Ensure that no dirt can get into the filter! This dirt can get into contact with and be discharged into the drinking water when the filter is switched back on. The health of people who drink dirty water is at risk.
- Store the filter in frost-free conditions! Frost can cause any water contained in the filter voids to freeze and thus cause mechanical damage to the filter so that it leaks at operating pressure or can burst. Leaking water can cause major damage

to the building. In addition, people near the filter can be injured by breaking off filter parts.

- When restarting the filter, follow the instructions for a new filter.

## 6. Faults

In order to ensure unit safety and leak tightness, only approved persons may open the units and replace parts subject to water pressure.

### Help with faults:

Fault	Cause	Remedy
Heating is cold!	The backwashing was not fully completed. The handwheel has not yet been turned back. (Ball valve handle at the front).	Turn the handwheel back to the right up to the limit stop. The filter is now back in the operating position!
	The heating system's circulating pump is defective.	Inform the fitter or your nearest customer service centre.
No backwashing water!	The expansion vessel or the heating system is depressurised.	Top up service water. Check the expansion vessel.
	A backflow preventer, a gravity brake or an automatic shut-off valve is installed in the direction of flow between the filter and the expansion filter.	Open the shut-off valve or if necessary install the filter in a more suitable location.
	In water heaters the heating circuit may be automatically shut-off by the heating of the water supply.	In this case you must wait until the service water has heated up.
Highly soiled backwashing water!	Backwashing intervals too long.	Reduce backwashing intervals.
Leak in the filter!		Inform fitter or nearest customer service centre.
Handwheel cannot be turned!		

## 7. Maintenance



(see chapter “Safety information and dangers due to non-compliance”)

Always observe the chapter on “Intended Use”!

### 7.1 Cleaning



(see chapter “Safety information and dangers due to non-compliance”)

**Only use clear, clean drinking water to clean the housing and transparent filter cover.**

Domestic all-purpose cleaners and glass cleaners can contain up to 25% solvents or alcohol (spirits).

These substances can chemically attack the plastic parts, which can lead to brittleness or even fractures.

**Such cleaners must therefore not be used.**

## 8. Warranty and Services

In order to receive your legal warranty rights, under DIN 1988, Part 8, it is necessary for the unit to be visually inspected and backwashed at least once before and after the heating period. If the heating water is severely soiled the backwashing must be repeated at 2-week intervals until a clear improvement occurs.

## 9. Data Sheet

### 9.1 Type

JUDO HEIFI-TOP Backwash filter with venting system

Abbreviated name: JHF-T

### 9.2 Models

Model	Order No.
JHF-T ¾"	8060030
JHF-T 1"	8060031
JHF-T 1¼"	8060032
JHF-T 1½"	8060033
JHF-T 2"	8060034

### 9.3 Technical Data

The following applies for all the models of the device:

- Maximum water temperature: 90°C
- Threaded connection to DIN 2999.

### Nominal Pressure

Model	Operating Pressure	Nominal Pressure
JHF-T ¾" – 2"	1.5 – 10 bar	PN 10

### Weight

Model	Weight
JHF-T ¾"	5.0 kg
JHF-T 1"	5.5 kg
JHF-T 1¼"	6.0 kg
JHF-T 1½"	15.0 kg
JHF-T 2"	16.0 kg

### Water flow rate

Model	Water flow rate up to	Pressure loss after back-washing
JHF-T ¾"	2 m³/h	0.02 bar
JHF-T 1"	3 m³/h	0.06 bar
JHF-T 1¼"	4 m³/h	0.10 bar
JHF-T 1½"	6 m³/h	0.06 bar
JHF-T 2"	8 m³/h	0.10 bar

### Back-flush Volume Stream

Model	Back-flush Volume Stream
JHF-T ¾"	0.2 - 0.4 l/s
JHF-T 1"	0.2 - 0.4 l/s
JHF-T 1¼"	0.2 - 0.4 l/s
JHF-T 1½"	0.2 - 0.4 l/s
JHF-T 2"	0.2 - 0.4 l/s

The backwashing volumetric flow given applies to 2-3 bar mains pressure and for a completely opened flushing water valve.

9.4 Installed dimensions  $\frac{3}{4}$ " -  $1\frac{1}{4}$ "

Model	A	B	C	D	E
JHF-T $\frac{3}{4}$ "	180	130	170	141	245
JHF-T 1"	195	130	170	141	245
JHF-T $1\frac{1}{4}$ "	230	130	175	141	245

All dimensions in [mm] (see Fig.6)

A = Installation length

B = unit width

C = Depth to pipe centre

D = Height below pipe centre

E = Height above pipe centre

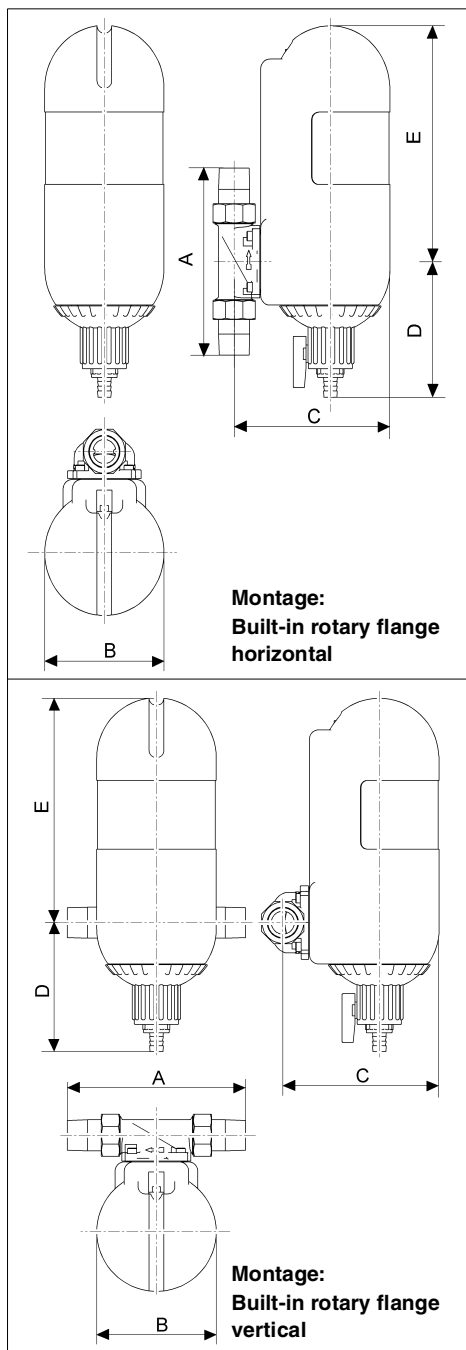

Fig. 6: Installed dimensions  $\frac{3}{4}$ " -  $1\frac{1}{4}$ "



**9.5 Installed dimensions 1½" - 2"**

Fig. 7: Installed dimensions 1½" - 2"

Model	A	B	C	D	E
JHF-T 1½"	252	234	342	141	245
JHF-T 2"	280	242	342	141	245

All dimensions in [mm] (see Fig.7)

A = Installation length

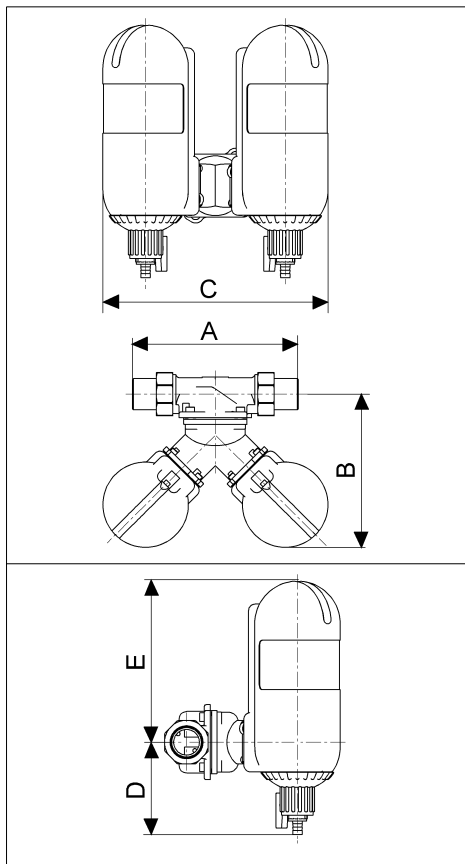
B = Depth to pipe centre

C = Unit width

D = Height below pipe centre

E = Height above pipe centre

**9.6 Extent of Supply**

- Pre-installed backwash filter
- Installation and Operating Instructions

**JHF-T ¾" – 1¼":**

- 1 x Built-in rotary flange  
JQE ¾", 1" or 1¼" with bayonet fixture and screw connection

**JHF-T 1½" – 2":**

- 1 x Built-in rotary flange  
JQE 1½" or 2" with bayonet fixture and screw connection

**9.7 Accessories JHF-T ¾" – 2"**

JHF-F feed station

Order No. 8060040

The JUDO HEIFI-FÜL feed station consists of a ball valve, pressure reducer, and manometer and type BA pipe disconnecter. The installed pressure reducer maintains a constant pressure and if the pressure drops the system is automatically topped up. This way the backwashing takes place with fresh water.

Ideally used in conjunction with the JUDO HEIFI-TOP backwash filter.

## 10. Spare Parts

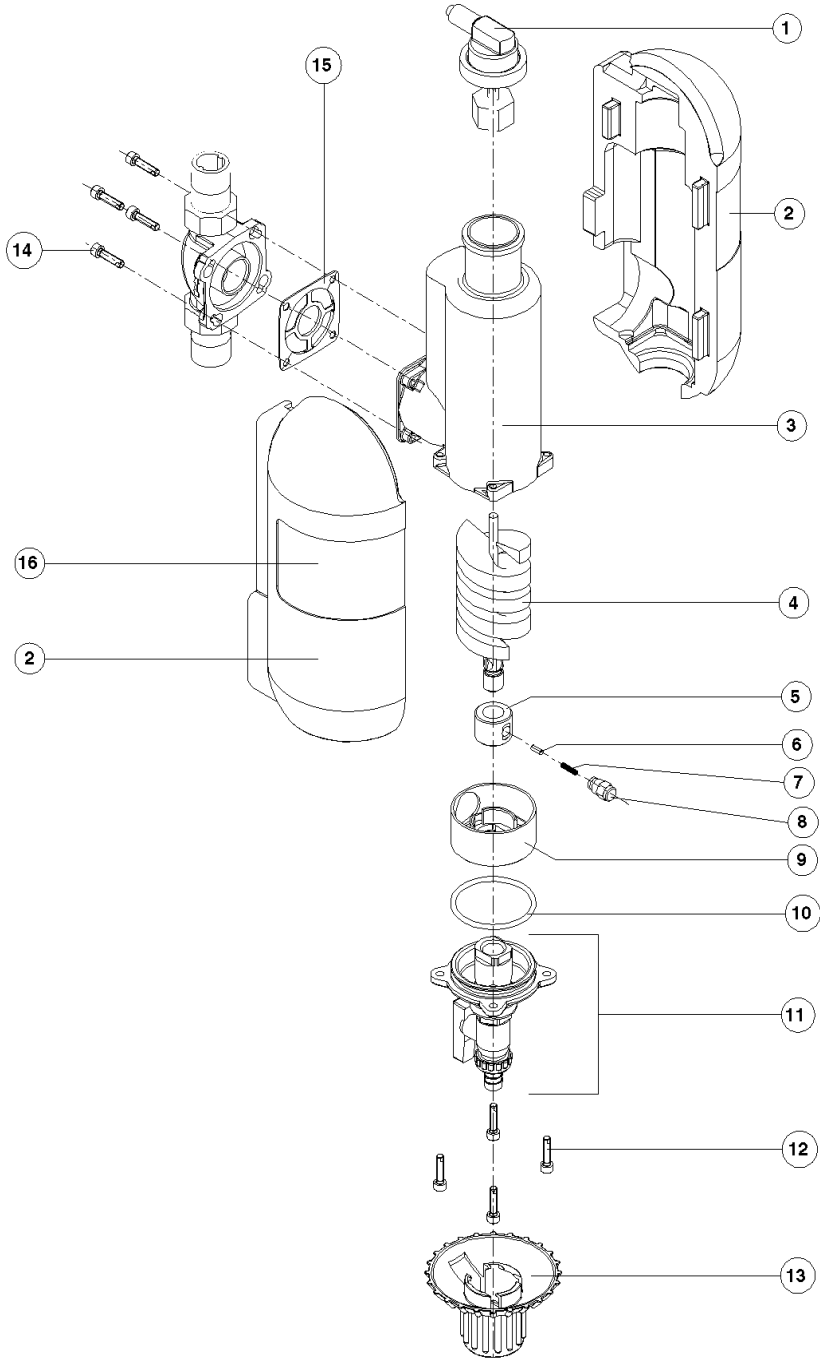

## List of Spare Parts JHF-T ¾" – 2"

Pos.	Designation (Recommended average replacement interval for wearable parts [**])	Piece(s)	Order No.	VE <sup>1)</sup> /Piece
1	Rapid venter *****	1	1980222	41
2	Insulating shells (set)	1	1140093	21
3	Housing JUDO HEIFI-TOP	1	2060073	183
4	Round brush d = 60 ****	1	1980214	43
5	Clamping nut	1	2060061	14
6	Cylindrical pin 4m 6 x 10	1	1650226	1
7	Pressure sprint	1	1650224	2
8	Self-locking housing	1	2060062	8
9	Shut-off valve	1	2060059	12
10	O-ring 61 x 4 ****	1	1633115	7
11	Complete driver cover ****	1	2060077	53
12	Cheese head screw M6 x 25	4	1633140	2
13	Handwheel	1	1120565	23
14	Cheese head screw M6 x 25	4	2010199	2
15	Profile flange seal **	1	1200218	5
16	JUDO HEIFI-TOP rating plate	1	1701136	8

1) VE = Unit of Billing

Replacement interval

\*\* = 2 years

\*\*\*\* = 4 years

\*\*\*\*\* = 5 years

Extended warranty period if a maintenance agreement is concluded!

## 11. Customer Service



### JUDO Wasseraufbereitung GmbH

Postfach 380 • D-71351 Winnenden  
 Tel. +49 (0)7195/6 92-0 • Fax: +49 (0)7195/6 92-188  
 e-mail: info@judo-online.de • www.judo-online.de



### JUDO France S.à.r.L

76 Rue de la Plaine des Bouchers • Technosud • F-67100 Strasbourg  
 Tel. +33 (0)3 88 65 93 94 • Fax +33 (0)3 88 65 98 49  
 e-mail: info@judo.fr • www.judo.fr



### JUDO BeNeLux

Kerkstraat 1 / 1 Rue de l'Eglise • B-1780 Wemmel  
 Tel. +32 (0)24 60 12 88 • Fax +32 (0)24 61 18 85  
 e-mail: info@judo-online.be • www.judo-online.be



### JUDO Austria

Zur Schleuse 5 • A-2000 Stockerau  
 Tel. +43 (0)2266 / 6 40 78 • Fax +43 (0)2266 / 6 40 79  
 e-mail: info@judo-online.at • www.judo-online.at

Installed by:

<p><b>JUDO BIostat-COMBI/-COMBIMAT</b>            The perfect combination of hygiene unit and lime protection unit. Prevents your installation from lime sedimentation and reduces morbid germs such as Legionella.</p>	<p><b>JUDO HEIFI-FÜL</b>            Automatic heating after supply station for compliance with DIN EN 1717, ideal in combination with JUDO HEIFI-TOP.</p>	<p><b>JUDO PROFI-PLUS / PROMI</b>            Backwashing protective filter / Germ protection class domestic water station with point rotation system for optimum cleaning of the filter insert.</p>
<p><b>JUDO BIOQUELL-SOFT</b>            Softener unit reduces water hardness, e.g. to hardness range 2.</p>	<p><b>JUDO JULIA</b>            Metering pump for JUL mineral solution against corrosion (brown water) and limescale deposits.</p>	<p><b>JUDO Thermodos metering solution</b>            For conditioning and cleaning hot water – heating circuits with less than 100 kW heating output</p>

All the illustrations, dimensions and information for the different models are those valid on the date of printing. All rights are reserved for modifications as a result of technical progress or further developments. Claims with regard to models or products are excluded.

1701470 • 2005/06