

Installation and Operating Instructions JUDO JRSF

Backwash Protective Filter 1" - 2"

Valid for: EU countries and Switzerland

Language: English

Attention:

Carefully read through the installation and operating instructions and safety information before installing and putting the unit into service.

These must always be issued to the owner/user.

Extended warranty period if a service agreement is concluded!



Fig.: JRSF 1" – 2"



Quiries, orders, customer support

JUDO Wasseraufbereitung GmbH
P.O. Box 380
D-71351 Winnenden

Phone: +49 (0)7195/6 92-0
Telefax: +49 (0)7195/6 92-188
internet: <http://www.judo-online.de>
e-mail: info@judo-online.de

Address

JUDO Wasseraufbereitung GmbH
Hohreuschstrasse 39-41
D-71364 Winnenden

Dear Customer,

We would like to thank you for your confidence in us, which you have shown by purchasing this device. The product you have purchased is a filter developed using state of the art technology.

This filter is suitable for use in cold drinking water up to a maximum ambient temperature of 30°C (86°F).

It removes coarse and fine-grained particles larger or equal in size to the filter screen (strainer) mesh from the filter through screen filtration.

Particles smaller than the screen mesh size used, turbidities (i.e. substances that make the water turbid) and substances dissolved in the water cannot be filtered out of the water.

Each unit is thoroughly checked before delivery. Should difficulties nevertheless occur, please contact the responsible customer service. See back page.

Trademarks:

Trademarks used in this document are protected and registered trademarks of the respective holder.

© JUDO Wasseraufbereitung GmbH
D-71351 Winnenden

All rights reserved.
Reprints – even of extracts – is only permitted with special approval.

Table of Contents

1. About this Instruction Manual..... 3

1.1 Symbols used 4

1.2 Safety information and dangers due to non-compliance 4

1.3 Units used..... 4

2. Intended Use 4

2.1 Water Pressure..... 5

2.2 Instructions Concerning Specific Dangers 5

3. Product Information 6

3.1 Intended purpose..... 6

3.2 Test marks..... 6

3.3 Materials used 6

4. Installation 6

4.1 General..... 6

4.2 Discharging the backwashing water 7

5. Operation 8

5.1 Commissioning 8

5.2 Funktional discription..... 8

5.3 Backwashing 9

5.4 Modifications / changes / spare parts..... 11

5.5 Stoppages 11

6. Faults 12

7. Maintenance..... 12

7.1 Cleaning 12

8. Warranty and Services..... 12

9. Data Sheet..... 13

9.1 Type..... 13

9.2 Models 13

9.3 Technical Data..... 13

9.4 Extent of Supply 13

10. Spare Parts JRSF 1" - 2" 14

11. Customer Service..... 16

Enclosure: Consultation Voucher

1. About this Instruction Manual



(see chapter “Safety information and dangers due to non-compliance”)

The instruction manual must be permanently available at the place in which the filter is used.

This instruction manual is intended to make it easier to familiarize yourself with the filter and its possible intended uses.

The instruction manual contains important information in order to safely, properly and economically run the filter.

It contains fundamental information, which must be observed during installation, operation and maintenance. Observance of this information helps to avoid dangers, reduce repair costs and increase the reliability and service life of the filter.

The instruction manual must be read and used by each person entrusted with carrying out work on the filter, for example:

- **Installation**
- **Operation**
- **Maintenance** (servicing, inspection, repair)

Installation and maintenance may only be carried out by personnel authorized by the manufacturer, who are capable of fulfilling the instructions given in the installation and operating instructions and the country-specific regulations.

Apart from the instruction manual and the legally binding accident prevention provisions applicable in the country and place of use, the recognized technical regulations for safe and proper work must also be observed.

Therefore, this instruction manual must always be read by the fitter and responsible skilled personnel/owner or operator before installation, putting into service and maintenance.

Not only the general safety notes given in the chapter “Intended Use” are to be observed, but also the special safety notes inserted under the other main items.

1.1 Symbols used

The safety notes contained in this instruction manual are labelled with the following symbols:



ATTENTION



Notes on existing dangers



Warning, electrical voltage.



Torques specified by the manufacturer.



Tips for use and other information.

Notes directly attached to the filter, e.g.

- Direction of flow
- Rating plate
- Cleaning information

must always be observed and kept in a fully legible condition.

1.2 Safety information and dangers due to non-compliance

In detail, failure to observe the general danger symbols can result, for example, in the following risks:

- Failure of important functions of the filter.
- Danger to persons due to electrical and mechanical effects.
- Danger to persons and the environment due to leaks.

Refrain from any unsafe working methods.

Failure to comply with this instruction manual and the safety information can not only result in dangers for people but can also harm the environment and the unit.

1.3 Units used

In derogation of the International System of Units (SI = System International), the following units are used:

Units	Conversion
°F	°F = 9/5°C + 32
bar	1 bar = 10 ⁵ Pa = 0,1 N/mm ²
1"	DN 25
1¼"	DN 32
1½"	DN 40
2"	DN 50

2. Intended Use

The installation and operation of the filter is subject to the following existing national regulations.

In addition to the operating instructions and the obliging regulations concerning accident prevention that exist in the country of operation and the location of use, the established technical regulations concerning safe and professional work, should also be observed.

The water which is to be treated should fulfil the requirements stipulated by European drinking water directives!

It is absolutely essential that the manufacturer / supplier will be consulted prior to any operation of the device using water of a different quality, respectively with water that contains additives.

This filter is designed for use with cold drinking water with a maximum water and environmental temperature of 30°C (86°F).

The filter has been developed and manufactured using state of the art technology and the established safety regulations in Germany.

The filter may only be operated in accordance with the manufacturer's specifications. Any other operation or operation beyond the specified use, is not in accordance with the manufacturer's specifications.

Additional dangers may result in the event of the device not being operated in accordance with the manufacturer's specifications and non-observance of the danger symbols or safety instructions. The manufacturer / supplier cannot be made liable for any damages caused by these additional dangers. The operator is responsible for these risks.

The use of the device in accordance with the customer's specifications includes the observance of the operating instructions.

The manufacturer / supplier should be consulted prior to any operation of the filter other than in the operational areas stated in these operating instructions.

The filter may only be operated in a technically faultless condition, in accordance with the manufacturer's specifications and the stated safety and danger relevant instructions and under observance of the operating instructions!

Any functional defects are to be removed immediately!

2.1 Water Pressure

The water pressure should be between 1.5 bar and 10 bar.

The water pressure must not exceed 1.5 bar as otherwise the backwashing can be impaired! If the filter is not backwashed regularly a pressure loss can result and this can impair the filter function.



ATTENTION

(see chapter "Safety information and dangers due to non-compliance")

In the event of **water pressure above 10 bar**, the pressure reduction valve should be fitted **in front** of the filter (see Fig. 1). If the operating pressure is above 10 bar, this may result in defects during operation.

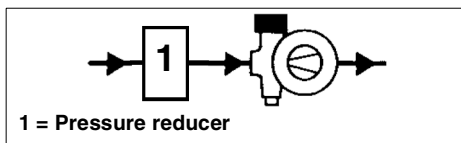

Fig. 1: Pressure reducer upstream of the unit



The installation of a pressure reduction valve is recommended for **water pressures between 5 bar and 10 bar**.

2.2 Instructions Concerning Specific Dangers

2.2.1 Electrical Devices / Equipment



Electrical wiring and devices may not be situated under or in the direct vicinity of the filter!

Electrical devices / equipment that are not splash-water proof and are situated in the direct vicinity of the filter may be damaged by water leaking from the filter caused as a result of the device not being operated in accordance with the manufacturer's specifications.

In addition this may also result short circuits if these electrical devices / equipment being connected to the electrical power supply. In the event of such cases persons are at risk and may sustain electrical shocks. Therefore any electrical devices / equipment situated in the direct vicinity should be splash-water proof, respectively comply with the statutory requirements for wet areas (IP44).

3. Product Information

3.1 Intended purpose

This filter is suitable for use in cold drinking water up to a water temperature of maximum 30°C (86°F).



(see chapter “Safety information and dangers due to non-compliance”)

Please refer to the chapter on “Intended Use” for use restrictions.

This filter removes coarse and fine-grained particles from the water which are larger than or equal in size to the mesh size of the filter.



Particles smaller than the supplied mesh size and impurities causing turbidity cannot be filtered out of the water.

3.2 Test marks

DIN-DVGW mark



Fig. 2: Test marks

The units conform to the technical regulations for drinking water installations in accordance with DIN 1988. They are tested by the DVGW (Deutsche Vereinigung des Gas- und Wasserfaches e.V. technical –scientific association for the gas and water industries) in accordance with the requirements of DIN 19632 pressure stage PN 16 for mechanical filters for use in drinking water and are entitled to bear the DIN-DVGW mark (see Fig. 2).

3.3 Materials used

The materials used are resistant to the physical, chemical, and corrosive loads to be expected in the drinking water and fulfil the requirements specified in DIN 19632 (“Mechanical filters in drinking water installations”). All materials are hygienically and physiologically safe. Plastics (KTW recommendations) and metallic materials fulfil the requirements of the BgVV (German Federal Institute for Consumer Health Protection and Veterinary Medicine).

4. Installation

4.1 General



(see chapter “Safety information and dangers due to non-compliance”)

The unit may only be installed by skilled personnel.

The chapter “Intended Use” must always be observed!

The pipes must be able to safely support the filter.

Otherwise mechanical damage or fractures/bursts can occur in the pipes. This can result in major water damage. People close to the filter are exposed to a health risk due to the large quantities of water released. Therefore, if necessary, the pipes must be additionally fixed or supported.

A space of at least 200 mm should be maintained above and below the filter. These distances are necessary to be able to properly carry out the backwashing (see chapter “Backwashing”).

4.1.1 Requirements for the place of installation

The room where the unit is installed must be dry and frost free!

Unauthorised persons must not have access to the filter!



(see chapter “Safety information and dangers due to non-compliance”)

- The ambient temperature must not exceed 30°C (86°F)! At higher temperatures or direct sun radiation the material can be damaged.
- In order to be able to safely discharge the wastewater in operation and in case of any defects that occur in the system, precise compliance with the details given in the “Installation” chapter is necessary! If the wastewater (backwashing) cannot be safely and completely discharged, the house and installations can be damaged by water.
- A shut-off valve must be installed upstream of the filter! This enables the water supply to the filter to be interrupted during installation, servicing/maintenance, repairs and in case of malfunctions. Floods and serious water damage to house installations can therefore be avoided.
- The unit can be installed in all standard drinking water pipes.
- It is not permitted to install the filter **upstream** of the water meter!

4.2 Discharging the backwashing water



(see chapter “Safety information and dangers due to non-compliance”)

An adequately dimensioned wastewater connection (e.g. floor drain) to DIN 1986 must be available for the backwashing water. If there is no wastewater connection an appropriately sized bucket can be used.

The dimensioning depends on the local circumstances (e.g. wastewater pipe gradient, number of pipe bends, length of the wastewater pipe, etc.). The dimensioning must at least allow all the wastewater to be discharged at the same time. If it is not possible to provide a wastewater connection directly beneath the filter, the flushing water can be fed several metres to the next wastewater connection, either through a hose or a pipe to be fitted to the flushing water valve. This pipe must have the same dimension as the flushing water valve.

In all options, a free discharge must be ensured in accordance with EN 1717.

The following points must be noted if a bucket is used for backwashing:

- If the mains pressure is high, water can splash out of the bucket. In this case, damage to property close to the filter is possible.
- When the bucket is half-filled the backwashing process must be stopped. Otherwise it is possible for the bucket to overflow. Therefore the bucket must be adequately dimensioned and the backwashing should be carried out quickly.

4.2.1 Backwashing water discharge options

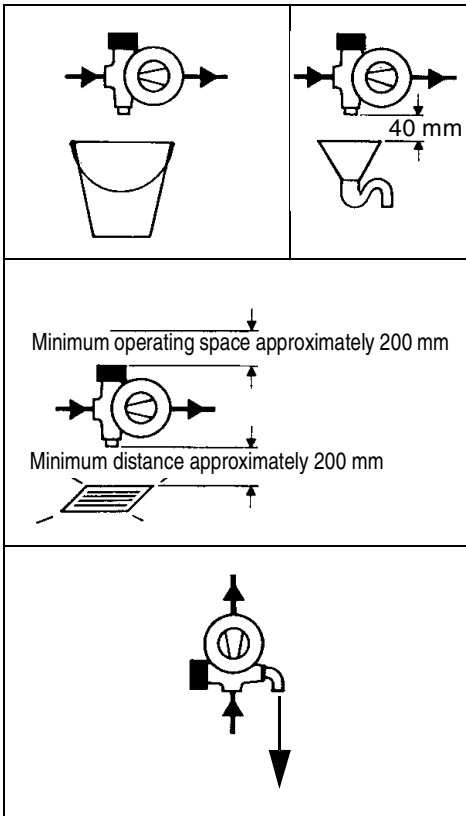

Fig. 3: Backwashing water discharge options

5. Operation



(see chapter “Safety information and dangers due to non-compliance”)

Always observe the chapter “Intended Use”!

5.1 Commissioning

Before starting up (initial putting into service or startup after maintenance work), **fill** the filter station with water and **vent!**

- To this end, after installation the filter station is filled with water by opening the upstream shut-off valve.
- The filter is now at the same pressure as the water system.
- The enclosed air must then be immediately removed from the filter station in order to avoid damage to the installation caused by pressure surges- The filter station is vented by means of backwashing (see chapter “Discharging the backwashing water”).
- After backwashing and venting the filter station is ready for use.

5.2 Funktional discription

The filter removes all coarse and fine-grained impurities which cause pitting in cold-water and hot-water supply lines and may lead to the malfunctioning of fitting and control elements, as well as sensitive instruments.

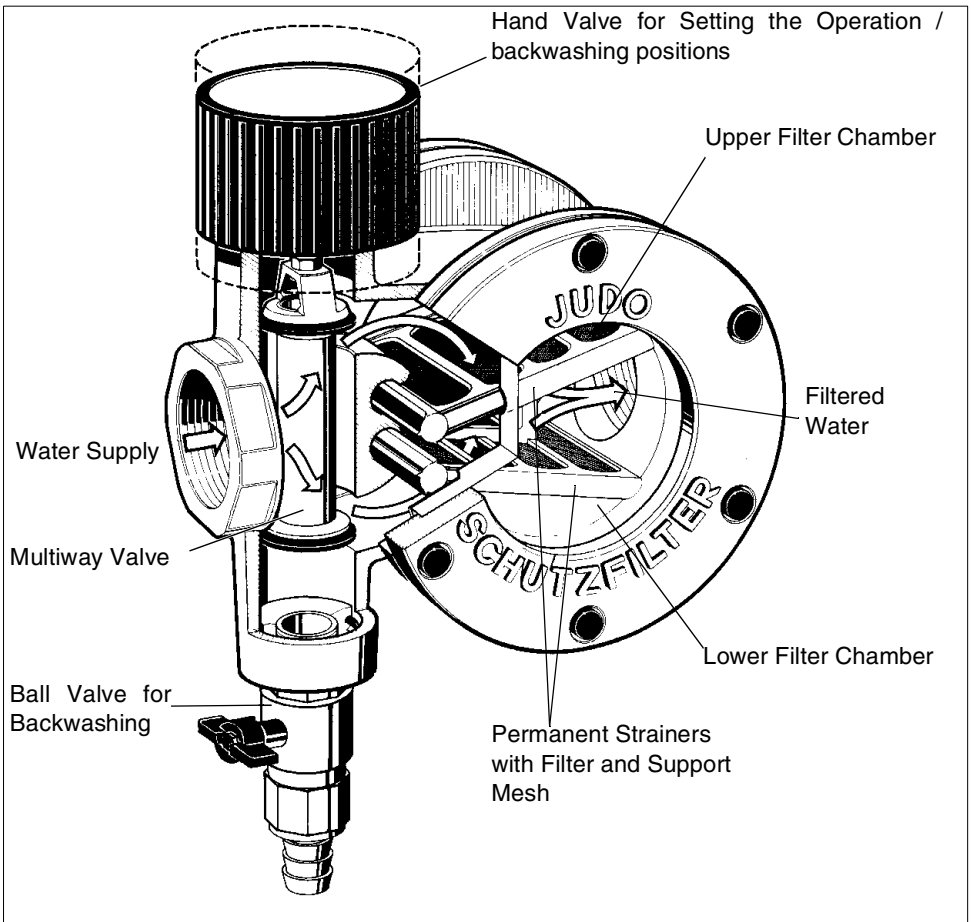

Fig. 4: Funktional discription

5.3 Backwashing

The filter must be backwashed (=cleaned) at the specified cycles in order to remove the filtered dirt from the fine filter screen.

i Both the degree of soiling and the cleaning process can be observed from the outside.

i All sizes of filter are backwashed with treated water. The supply of treated water to the filter station is maintained throughout the backwashing process. Dirty water cannot get into the clean water side during backwashing.

Depending on the water-flow volume and the kind and extent of coarse and fine-grained impurities found in the water, filter is to be flushed back at 1 to 3-month intervals, **unless serious pollutants necessitate backwashing at shorter intervals.**

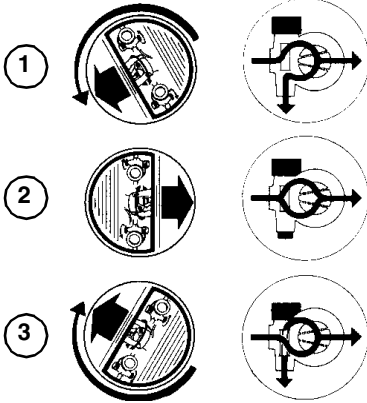

Fig. 5: Backwashing

1 Hand valve turned upward:

Backwashing the lower filter chamber while simultaneously supplying water via the upper filter chamber.

2 Hand valve in mid-position:

Water supplied via both filter chambers.

3 Hand valve turned downward:

Backwashing the upper filter chamber while simultaneously supplying water via the lower filter chamber.

Backwashing is done at full water-tap pressure. Open the ball valve. Turn hand valve to one side (1) for about 2 to 5 seconds **until the stop is reached** (at least $\frac{1}{2}$ rotation). Subsequently turn the hand valve in the other direction (3). **If the filter is very soiled, repeat this procedure several Times.**

Then turn the hand valve again to mid-position (2), so that the arrow on the hand valve points to the direction of flow. Close the ball valve. In case of high water pressure, it is advisable not to fully open the ball valve in order to reduce the consumption of flushing water.

5.3.1 Backwashing interval

The filter must be backwashed:

- Every two months at the latest.
- If the water pressure falls.
- If the filter is visibly dirty.



(see chapter “Safety information and dangers due to non-compliance”)

If the interval until the next backwashing is longer than two months, the particles on the filter screen can stick or a large filter pressure resistance can result.

Unauthorised persons must not operate the filter! Persons who operate the filter must observe the operating instructions. Failure to observe these instructions can result in damage to property and personal injuries.

The smaller the mesh size of the screen insert the more frequently backwashing is required!

From experience, increased dirt is deposited during the initial running period. In this case the unit will have to be flushed more frequently than normal.

Failure to flush in good time can cause damage to the screen. Large quantities of filtered particles can deform the screen. As a result, proper function of the filter is no longer ensured. In addition, large quantities of dirt can cause mechanical damage to the backwashing function.

5.4 Modifications / changes / spare parts



ATTENTION



(see chapter “Safety information and dangers due to non-compliance”)

Only original spare parts are to be used!

Independent modifications and changes are prohibited for safety reasons! These can impair the function of the filter, lead to lead and in extreme cases can cause the filter to burst.

The test marks imprinted on the unit are only valid if original spare parts are used.

- Ensure that no dirt can get into the filter! This dirt can get into contact with and be discharged into the drinking water when the filter is switched back on. The health of people who drink dirty water is at risk.
- Store the filter in frost-free conditions! Frost can cause any water contained in the filter voids to freeze and thus cause mechanical damage to the filter so that it leaks at operating pressure or can burst. Leaking water can cause major damage to the building. In addition, people near the filter can be injured by breaking off filter parts.
- When restarting the filter, follow the instructions for a new filter.

5.4.1 Servicing / Repair

Before carrying out any work on the filter, which extends beyond pure operational control, the filter must be depressurised! Failure to observe this can lead to an uncontrolled escape of water and therefore lead to water damage in the building. Strictly comply with the instructions given in the “Installation” and “Maintenance” chapters.

5.5 Stoppages



ATTENTION



(see chapter “Safety information and dangers due to non-compliance”)

If a filter has to be removed from the flange or unscrewed, the chapter “Intended use” must always be observed!

- Protect the flange surfaces from damage! Damaged flanged surfaces cannot close tight. As a result, escaping water can damage the building and installations.

6. Faults

In order to ensure unit safety and leak tightness, only approved persons may open the units and replace parts subject to water pressure.

Help with faults:

Fault	Cause	Remedy
Backwashing water continues running!	Ball valve not fully closed.	Repeat the backwashing and then turn the handwheel until it locks into place!
Water flow rate falls!	Screen is blocked.	Carry out backwashing.
Leaks in the filter!	Filter has been exposed to high temperatures or solvents.	Inform the fitter or nearest customer service centre. (The filter cover must be replaced immediately.)
Sight glass becomes turbid!		
Hairline cracks on the Sight glass!		

7. Maintenance



(see chapter “Safety information and dangers due to non-compliance”)

Always observe the chapter “Intended Use”!

7.1 Cleaning



(see chapter “Safety information and dangers due to non-compliance”)

Only use clear, clean drinking water to clean the housing.

Domestic all-purpose cleaners and glass cleaners can contain up to 25% solvents or alcohol (spirits).

Such cleaners must therefore not be used.

8. Warranty and Services

In order to comply with the legal warranty claim, according to DIN 1988, Part 8, it is necessary that the "... backwashing takes place at least every 2 months, after operating conditions exist ...".

Regular servicing is indispensable in order to continue to achieve a successful process for many years after the unit is put into service. In the building services sector this is covered by DIN 1988, Part 8.

A servicing agreement is the best way to ensure a good operating function beyond the warranty period.

Wherever possible, the regular servicing work and supply with consumables and wearing materials, etc. should be carried out by the specialist trade or the factory's customer service department.

9. Data Sheet

9.1 Type

JUDO JRSF Backwash Protective Filter

Abbreviated name: JRSF

9.2 Models

Model	Order No.
JRSF 1"	8030081
JRSF 1¼"	8030082
JRSF 1½"	8030076
JRSF 2"	8030070

9.3 Technical Data

The following applies for all the models of the device:

- The filters are supplied with a stainless steel screen with a mesh size of 0.1 mm as a standard.
- Pressure loss when clean (after backwashing): 0.2 bar at the water flow rate (nominal flow rate) given in the table.
- Maximum ambient temperature and water temperature: 30°C (86°F)
- **The water to be filtered must conform to the European Drinking Water Regulations!**
- Threaded connection to DIN 2999.

Nominal Pressure

Model	Operating Pressure	Nominal Pressure
JRSF ¾" – 2"	1.5 – 10 bar	PN 16

Weight

Model	Weight
JRSF 1"	7.0 kg
JRSF 1¼"	7.0 kg
JRSF 1½"	12.0 kg
JRSF 2"	12.0 kg

Water flow rate

Model	Nominal Flow Rate up to	Pressure at Nominal Flow Rate
JRSF 1"	5.0 m³/h	0,2 bar
JRSF 1¼"	6.0 m³/h	0,2 bar
JRSF 1½"	14.0 m³/h	0,2 bar
JRSF 2"	15.0 m³/h	0,2 bar

9.4 Extent of Supply

- Pre-installed Backwash Protective Filter
- Installation and Operating Instructions

10. Spare Parts JRSF 1" - 2"

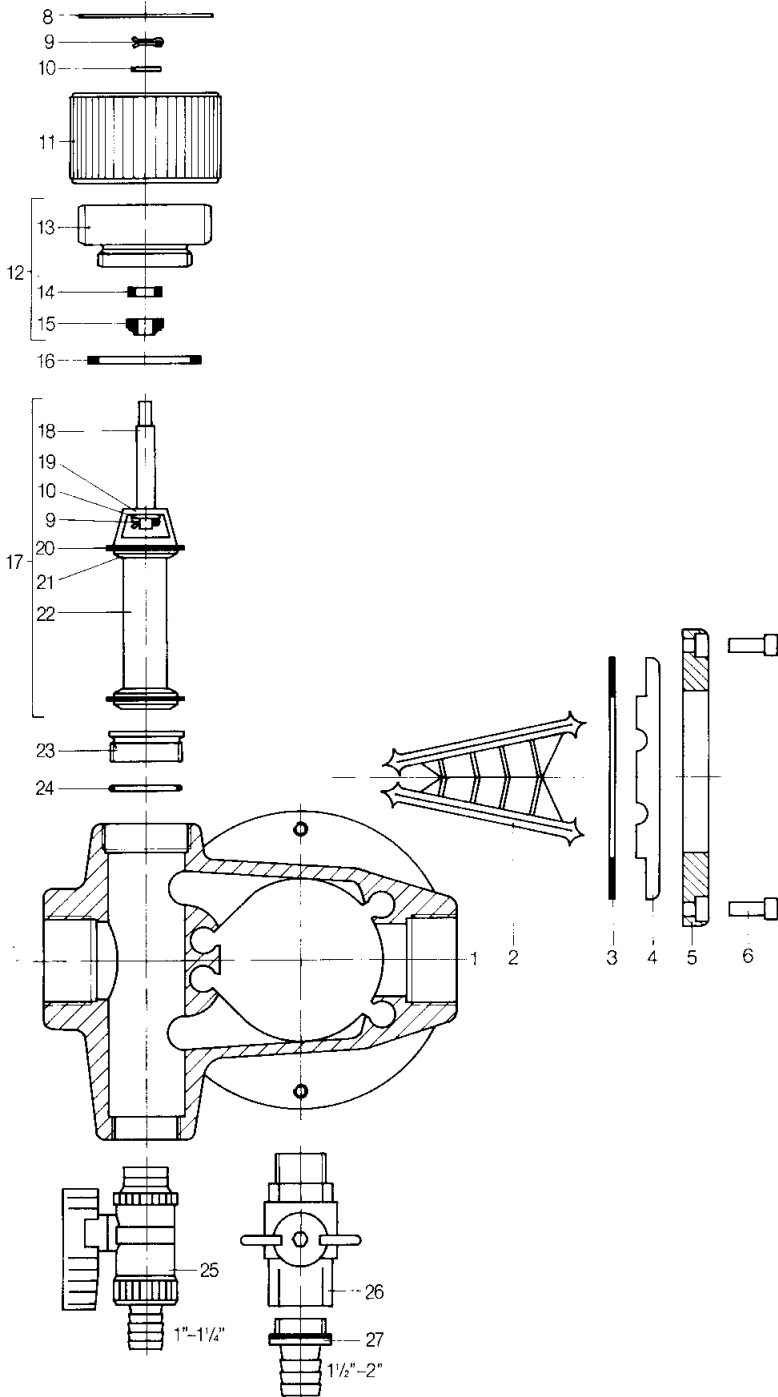

List of Spare Parts JRSF 1" - 2"

Pos.	Designation (Recommended average replacement interval for wearable parts [*])	Pieces(s)	1" - 1¼"	VE ¹⁾ / Piece	1½" - 2"	VE ¹⁾ / Piece
			Order No.		Order No.	
1	Housing R 1"	1	2610121	263	-	-
1	Housing R 1¼"	1	2611121	278	-	-
1	Housing R 1½"	1	-	-	2612121	328
1	Housing R 2"	1	-	-	2613121	347
2	Strainer, 0.1 mm	**** 2	2030141	50	2030142	73
3	Web seal	**** 2	1610124	5	1612124	8
4	Sight glass	**** 2	2610125	52	2612125	72
5	Cover	2	2610126	59	2612126	67
6	Cheese-head screw	12	1633347	1	1612127	2
8	Identification plate R 1"	1	1610148	4	-	-
8	Identification plate R 1¼"	1	1700102	4	-	-
8	Identification plate R 1½"	1	-	-	1612148	7
8	Identification plate R 2"	1	-	-	1700103	7
9	Splint	2	1610139	1	1612139	2
10	Disk	2	1607156	1	1607125	1
11	Hand valve	1	1610147	15	1612147	22
12	Threaded flange, complete, items 13-15	1	2610150	62	2612150	79
13	Threaded flange	1	1610146	51	1612146	66
14	Lip seal	**** 1	1610145	5	1612145	6
15	Scraper ring	**** 1	1610149	6	1612149	7
16	Flat gasket	**** 1	1610144	4	1612144	6
17	Slide valve, complete, items 9,10, 18-22	1	2030056	106	2030057	129
18	Valve spindle	1	1610143	9	1612143	16
19	Head of slide valve	1	1610137	14	1612137	23
20	Gasket	**** 2	1610140	4	1612140	4
21	Washer	3	1610141	6	1612141	8
22	Connecting pipe	1	1610142	18	1612142	21
23	Reducing nipple	1	1 440061	13	1440062	22
24	O-ring 28x2.5	1	1200027	3	-	-
24	O-ring 38x4	1	-	-	1612131	6
25	Spherical faucet, complete, JRSF 1" & 1¼"	1	1610006	24	-	-
26	Spherical faucet JRSF 1½" & 2"	1	-	-	1610252	88
27	Hose nozzle JRSF 1½" & 2"	1	-	-	1440060	12

1) VE = Unit of Billing

Replacement interval: **** = 4 years

Extended warranty period if a maintenance agreement is concluded!

11. Customer Service



JUDO Wasseraufbereitung GmbH

Postfach 380 • D-71351 Winnenden
 Tel. +49 (0)7195/6 92-0 • Fax: +49 (0)7195/6 92-188
 e-mail: info@judo-online.de • www.judo-online.de



JUDO France S.à.r.L

76 Rue de la Plaine des Bouchers • Technosud • F-67100 Strasbourg
 Tel. +33 (0)3 88 65 93 94 • Fax +33 (0)3 88 65 98 49
 e-mail: info@judo.fr • www.judo.fr



JUDO BeNeLux

Kerkstraat 1 / 1 Rue de l'Eglise • B-1780 Wommel
 Tel. +32 (0)24 60 12 88 • Fax +32 (0)24 61 18 85
 e-mail: info@judo-online.be • www.judo-online.be



JUDO Austria

Zur Schleuse 5 • A-2000 Stockerau
 Tel. +43 (0)2266 / 6 40 78 • Fax +43 (0)2266 / 6 40 79
 e-mail: info@judo-online.at • www.judo-online.at

Installed by:

JUDO BIOQUELL-SOFT Softener unit reduces water hardness, e.g. to hardness range 2.	JUDO JULIA Metering pump for JUL mineral solution against corrosion (brown water) and limescale deposits.	JUDO HEIFI-KOM Combination of the heating backwashing filter and automatic heating feed station for fulfilment of DIN EN 1717.
JUDO Backwash Protective Filter SPEEDYMAT-LongLife Automatic Backwash Protective Filter Automatic in the long-life class with patented ceramic flushing valve backwashing technique.	JUDO ZEWA WATER STOP Central water safety fitting. Stops water flow in the event of water pipe bursts and detects leaks.	JUDO BIostat-COMBI / -COMBIMAT The perfect combination of hygiene unit and lime protection unit. Prevents your installation from lime sedimentation and reduces morbid germs such as Legionella.

All the illustrations, dimensions and information for the different models are those valid on the date of printing. All rights are reserved for modifications as a result of technical progress or further developments. Claims with regard to models or products are excluded.

1701472 • 2005/05