

# Installation and operating instructions

## JUDO MAFI Magnetite filter

Heating loop filtration with magnetic and centrifugal extraction and integrated aeration unit

Valid for: EU countries and Switzerland

Language: English

---

### Attention:

Carefully read through the installation and operating instructions and safety information before installing and putting the unit into service.

These instructions must always be issued to the owner/user.

---

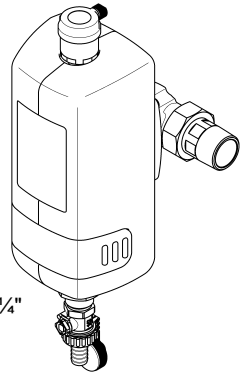

Fig.: JMFI 3/4" - 1/4"

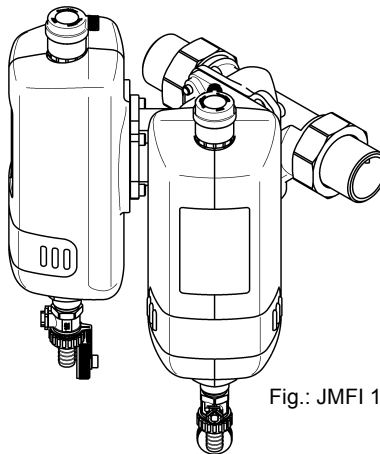

Fig.: JMFI 1/2"



---

**Inquiries, orders, customer support**

JUDO Wasseraufbereitung GmbH  
P.O. Box 380  
71351 Winnenden  
Germany  
e-mail: info@judo.eu  
judo.eu

**Address**

JUDO Wasseraufbereitung GmbH  
Hohreuschstraße 39 - 41  
71364 Winnenden  
Germany

**Dear customer,**

**thank you for the confidence you have shown in us by purchasing this unit. With this magnetite filter you have purchased a state of the art unit.**

**This multi-functional unit is designed for use in heating loop systems and features a centrifugal particle removal system, a magnetic removal unit and an integrated aeration feature.**

**The unit removes physical impurities in the loop (e.g. rusty sludge) which can lead to malfunctions in the control and regulation mechanisms in the system and the high-grade magnet traps the sludge (magnetite) within the unit.**

**The integrated aeration unit allows for the removal of corrosive gases in solution (eg. Hydrogen and oxygen)**

**Each unit is thoroughly checked before delivery. Should difficulties occur, please contact the responsible customer service (see back page).**

Trademarks:

Trademarks used in this document are protected and registered trademarks of the respective holder.

© JUDO Wasseraufbereitung GmbH  
71364 Winnenden  
Germany

All rights reserved.

Reprints – even of extracts – is only permitted with special approval.

**Table of contents**

**1. About this instruction manual..... 3**  
 1.1 Symbols used ..... 4  
 1.2 Safety information and dangers due to non-compliance ..... 4  
 1.3 Units used..... 4  
**2. Intended use ..... 5**  
 2.1 Water pressure ..... 5  
 2.2 Notes on special dangers ..... 5  
**3. Product information ..... 6**  
 3.1 Intended purpose..... 6  
**4. Installation ..... 6**  
 4.1 General..... 6  
 4.2 Installation position ..... 7  
 4.3 Installation schematics ..... 7  
 4.4 Mounting the built-in rotary flange..... 9  
 4.5 Mounting the magnetite filter ..... 9  
 4.6 Discharging the rinse water ..... 10  
 4.7 Dangers during rinsing ..... 10  
**5. Operation ..... 11**  
 5.1 Commissioning ..... 11  
 5.2 Functional description..... 11  
 5.3 Cleaning the magnetic separator ..... 13  
 5.4 Rinsing..... 14  
 5.5 Rinse interval..... 14  
 5.6 Modifications / changes / spare parts..... 14  
 5.7 Stoppages ..... 15  
**6. Faults ..... 16**  
**7. Maintenance ..... 17**  
 7.1 Cleaning ..... 17  
**8. Warranty and services ..... 17**  
**9. Data sheet ..... 18**  
 9.1 Type..... 18  
 9.2 Models ..... 18  
 9.3 Technical specifications..... 18  
 9.4 Installation dimensions ..... 19  
 9.5 Scope of supply ..... 19  
 9.6 Accessories ..... 19  
**10. Spare parts ..... 20**  
**11. Customer service ..... 24**

**1. About this instruction manual**



(see chapter “Safety information and dangers due to non-compliance”)

The instruction manual must be permanently available at the place in which the magnetite filter is used.

This instruction manual is intended to make it easier to familiarize yourself with the magnetite filter and its possible intended uses.

The instruction manual contains important information in order to safely, properly and economically run the magnetite filter.

It contains fundamental information, which must be observed during installation, operation and maintenance. Observance of this information helps to avoid dangers, reduce repair costs and increase the reliability and service life of the magnetite filter.

The instruction manual must be read and used by each person entrusted with carrying out work on the magnetite filter, for example:

- **Installation**
- **Operation**
- **Maintenance**  
(servicing, inspection, repair)

Installation and maintenance may only be carried out by personnel authorized by the manufacturer, who are capable of fulfilling the instructions given in the installation and operating instructions and the country-specific regulations.

Apart from the instruction manual and the legally binding accident prevention provisions applicable in the country and place of use, the recognized technical regulations for safe and proper work must also be observed.

Therefore, this instruction manual must always be read by the fitter and responsible skilled personnel/owner or operator before

installation, commissioning and maintenance.

**Not only the general safety notes given in the chapter “Intended use” are to be observed, but also the special safety notes inserted under the other main items.**

### 1.1 Symbols used

The safety notes contained in this instruction manual are labelled with the following symbols:

 **ATTENTION**  Notes on existing dangers

 Warning, electrical voltage

 Hot surface

 Torques specified by the manufacturer

 Do not use if you wear a pace maker!

Notes directly attached to the magnetite filter, e.g.

- Hot surface do not touch
- Labelling
- Cleaning instructions

must always be observed and kept in a fully legible condition.

### 1.2 Safety information and dangers due to non-compliance

In detail, failure to observe the general danger symbols can result, for example, in the following risks:

- Failure of important functions of the magnetite filter.
- Danger to persons due to electrical and mechanical effects.
- Danger to persons and the environment due to hot water leakage. Danger of scalding!

Refrain from any unsafe working methods.

Failure to comply with this instruction manual and the safety information can not only result in dangers for people but can also harm the environment and the unit.

### 1.3 Units used

In derogation of the International System of Units SI (Système International d’Unités), the following units are used:

Units	Conversion
bar	1 bar = 10 <sup>5</sup> Pa = 0.1 N/mm <sup>2</sup>
1"	DN 25

## 2. Intended use

Installation and use of the magnetite filter are each subject to the applicable national regulations.

In addition to the operating instructions and the obliging regulations concerning accident prevention that exist in the country of operation and the location of use, the established technical regulations concerning safe and professional work, should also be observed.

The magnetite filter is produced to state of the art standards and the generally accepted safety regulations in Germany.

The magnetite filter may only be used as described in the instruction manual. Any other or further use is deemed not to be intended use.

Additional dangers exist in case of non-intended use and failure to observe the danger symbols and safety information. The manufacturer/supplier are not liable for any losses or damage resulting from this. The risk is solely borne by the user.

Intended use also includes observing the instruction manual.

The manufacturer/supplier must always be consulted before using the magnetite filter outside the use limitations given in the instruction manual.

The magnetite filter is only to be used in a technically perfect condition, for its intended use, safely and aware of the dangers and with full observance of the instruction manual!

**Have any malfunctions corrected immediately!**

## 2.1 Water pressure

Water pressure should not sink below 1 bar as this will affect the efficiency when flushing sludge out of the unit! Pressure within the system should be checked after flushing as a top up may be required.

## 2.2 Notes on special dangers

### 2.2.1 Electrical devices/equipment



There must not be any electrical cables and devices underneath or in the immediate vicinity of the magnetite filter!

Electrical devices/equipment that are not splash-water proof and are situated in the direct vicinity of the magnetite filter may be damaged by water leaking from the magnetite filter when flushing or by non-correct usage. In addition this may also result short circuits if these electrical devices/equipment being connected to the electrical power supply. In the event of such cases persons are at risk and may sustain electrical shocks. Therefore any electrical devices/equipment situated in the direct vicinity should be splash-water proof, respectively comply with the statutory requirements for wet areas (IP44).

## 3. Product information

### 3.1 Intended purpose

This magnetite filter is for use in heating loops up to a max. heating water temperature of 90 °C and a max. operating pressure of 6 bar.

Do not install in drinking water systems!

## 4. Installation

### 4.1 General



(see chapter “Safety information and dangers due to non-compliance”)

The unit may only be installed by skilled personnel.

The chapter “Intended use” must always be observed!

The pipes must be able to safely support the magnetite filter.

Otherwise mechanical damage or fractures/bursts can occur in the pipes. This can result in major water damage. People close to the magnetite filter are exposed to a health risk due to hot water released. Therefore, if necessary, the pipes must be additionally fixed or supported.

For convenient operation and maintenance it is absolutely necessary to ensure the given spacings (see chapter “Installation dimensions”). A space of at least 250 mm should be maintained above and below the magnetite filter. These distances are necessary to obtain an efficient rinse (see chapter “Rinsing”).

### 4.1.1 Requirements for the place of installation

**The room where the unit is installed must be dry and frost free! Unauthorised persons must not have access to the magnetite filter!**



(see chapter “Safety information and dangers due to non-compliance”)

- This magnetite filter is designed for use in heating loop systems and can be installed in both the supply and return sections of the loop. Where no maintenance during heating operation is possible, a bypass should also be installed.
- In order to be able to safely discharge the wastewater (rinsing) in operation and in case of any defects that occur in the system, precise compliance with the details given in the “Installation” chapter is necessary!  
If the wastewater (backwashing) cannot be safely and completely discharged, the house and installations can be damaged by water.
- A shut-off valve must be installed upstream and downstream of the magnetite filter! This enables the water supply to the magnetite filter to be interrupted during installation, servicing/maintenance, repairs and in case of malfunctions. Floods and serious water damage to house installations can therefore be avoided.
- Consult your sales agent regarding suitability of this unit for use with heating water conditioning agents used by you.

## 4.2 Installation position



**ATTENTION**

(see chapter "Safety information and dangers due to non-compliance")

Always install the magnetite filter in a vertical position ( $\pm 5^\circ$ )! Tensions which may

arise, eg. due to temperature fluctuations, may eventually require the installation of suitable expansion joints. Avoid changing loads like pressure surges and high levels of vibration.

The aeration unit must point upwards. This is the only way to guarantee a proper functioning.

## 4.3 Installation schematics

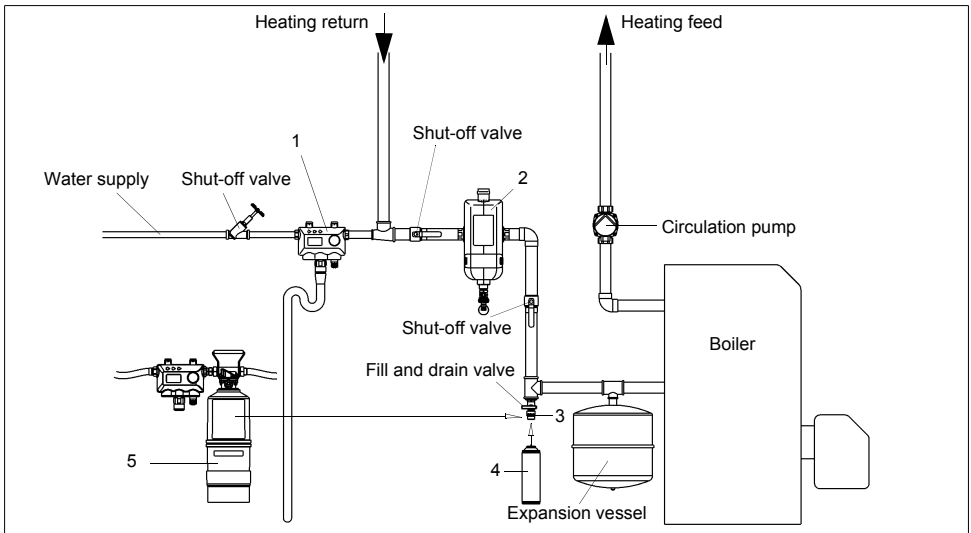

Fig. 1: Schematic JUDO MAFI with mobile heating water conditioning according to VDI 2035

- 1 **JUDO HEIFI-FÜL PLUS**  
Heating resupply station with integrated pipe disconnecter, type BA (order no.: 8060080)
- 2 **JUDO MAFI**  
Magnetite filter  $\frac{3}{4}$ " / 1" /  $1\frac{1}{4}$ " /  $1\frac{1}{2}$ " (order no.: 8060083 / 8060084 / 8060085 / 8060086)
- 3 **JUDO QUICK-AN**  
Adaptor for dosing with QUICK-DOS (order no.: 8838188)
- 4 **JUDO QUICK-DOS L / JUDO QUICK-DOS R / JUDO QUICK-DOS PLUS / JUDO QUICK-DOS MINUS**  
Cleaning and protection agents for heating circuits (order no.: 8838185 / 8838186 / 8650015 / 8650016)
- 5 **JUDO HEIFI-SOFT**  
Heating system filling with mobile softening bottle (order no.: 8068501)

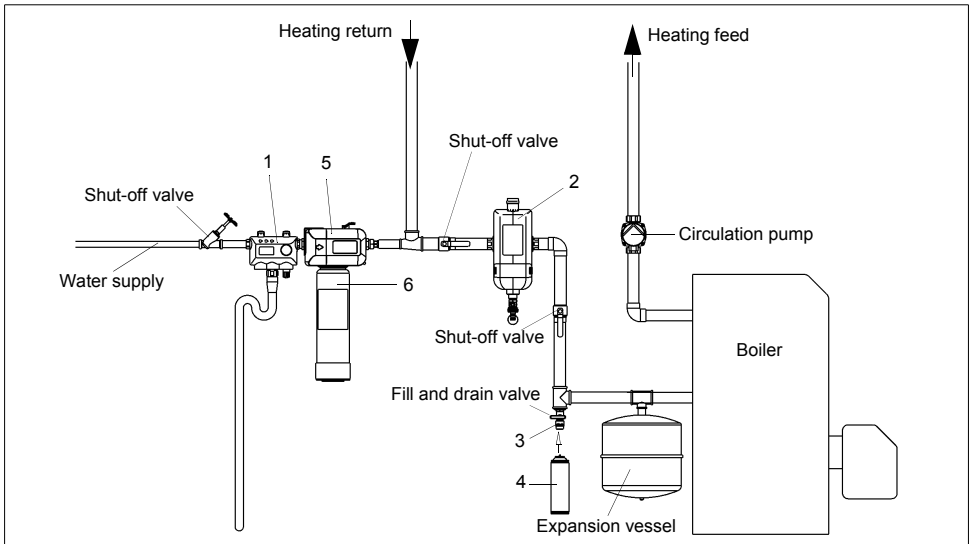

Fig. 2: Schematic JUDO MAFI with fixed heating water conditioning according to VDI 2035

- 1 **JUDO HEIFI-FÜL PLUS**  
Heating resupply station with pipe disconnecter, type BA (order no.: 8060080)
- 2 **JUDO MAFI**  
Magnetite filter ¾" / 1" / 1¼" / 1½" (order no.: 8060083 / 8060084 / 8060085 / 8060086)
- 3 **JUDO QUICK-AN**  
Adaptor for dosing with QUICK-DOS (order no.: 8838188)
- 4 **JUDO QUICK-DOS L / JUDO QUICK-DOS R / JUDO QUICK-DOS PLUS / JUDO QUICK-DOS MINUS**  
Cleaning and protection agents for heating circuits (order no.: 8838185 / 8838186 / 8650015 / 8650016)
- 5 **JUDO HEIFI PURE filling block 7500**  
Fill water demineralisation unit (order no.: 8068013)  
or  
**JUDO HEIFI SOFT filling block 12000**  
Fill water softening unit (order no.: 8068012)
- 6 **JUDO PURE 7500** Full demineralisation cartridge (order no.: 8068019),  
or alternatively the floor-standing version **JUDO PURE 25000** Full demineralisation cartridge (order no.: 8068531) with adaptor kit (order no.: 8068532)  
**JUDO SOFT 12000** Softening cartridge (order no.: 8068018),  
or alternatively the floor-standing version **JUDO SOFT 60000** Softening cartridge (order no.: 8068530) with adaptor kit (order no.: 8068532)



#### 4.4 Mounting the built-in rotary flange

Install using the supplied built-in rotary flange. The built-in rotary flange is used as a connecting element with the heating circuit.

It is suitable for both horizontal and vertical pipes.

**The built-in rotary flange must be installed in the direction of flow. This is marked by a cast in arrow (see fig. 3).**

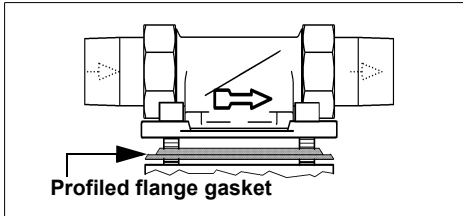

Fig. 3: Built-in rotary flange

Failure to comply with this means that the magnetite filter cannot work.



**ATTENTION**

(see chapter "Safety information and dangers due to non-compliance")

The flange surface of the built-in rotary flange must be in a vertical position! The built-in rotary flange must be fitted so that mechanical stresses cannot occur! Otherwise mechanical damage can result, the pipe may burst or the built-in rotary flange can break. This can result in major water damage.

In this case, people close to the magnetite filter are exposed to a health risk due to the large quantities of water.

Therefore, during installation, ensure that no large forces act on the pipe, built-in rotary flange and magnetite filter.

#### 4.5 Mounting the magnetite filter

The built-in rotary flange for the magnetite filter is supplied with bayonet drill holes. The necessary seals and screws for this magnetite filter have already been mounted.

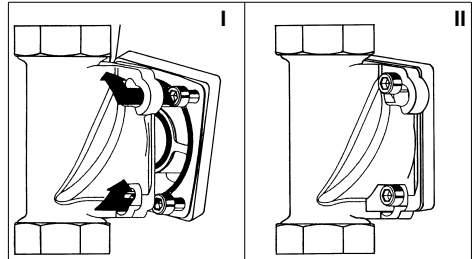

Fig. 4: Built-in rotary flange with bayonet fixture

**Do not unscrew the screws!**

- Insert the four flange screws in the bayonet drill holes on the built-in rotary flange (see fig. 4 I).
- Turn the magnetite filter in a clockwise direction as far as it will go (see fig. 4 II).
- Tighten the four flange screws.



Select the torque (approx. 4 Nm) so that the gasket closes and the magnetite filter is not damaged or strained!

The section of the profiled flange gasket must point towards the built-in rotary flange (see fig. 3). Failure to observe this can lead to leaks and water escaping. This can in turn cause water damage to the house and its installations.

#### 4.6 Discharging the rinse water



(see chapter “Safety information and dangers due to non-compliance”)

For the rinse water a wastewater connection (for example a floor drainage) in accordance with DIN 1986 must be in place. If there is no wastewater connection an appropriately sized bucket can be used.

#### 4.7 Dangers during rinsing



(see chapter “Safety information and dangers due to non-compliance”)

During the rinsing operation, hot water comes out of the outlet nozzle.

##### **Carry out with care, danger of scalding!**

The following points must be noted if a bucket is used for rinsing:

- If the pressure is high, water can splash out of the bucket, and the end of the hose can pop out from the bucket.

##### **Danger of scalding!**

- In this case, damage to property close to the magnetite filter is possible.
- The bucket must be adequately dimensioned.



**Danger, hot surface!**

## 5. Operation



(see chapter “Safety information and dangers due to non-compliance”)

Always observe the chapter “Intended use”!

### 5.1 Commissioning

Before starting up (initial putting into service or startup after maintenance work), **fill** the magnetite filter with water! Observe the following:

- Close or keep closed the shut-off valve downstream of the unit to ensure that air cannot be introduced into the system.
- Open the shut-off valve upstream of the unit.
- The magnetite filter is now under operating pressure.
- Air trapped within the unit is now automatically removed via the integrated aeration unit. We recommend a rinse after aeration (see chapter “Rinsing”).
- The filter comes delivered with the cover cap (1) on the aeration unit (2) being open one turn to ensure air can be evacuated freely (see fig. 5).
- The magnetite filter is ready for operation once the rinsing and aeration cycle has been completed and the shut-off valve downstream of the unit has been opened.

## 5.2 Functional description

### Centrifugal separator

Heating water flows through the built-in rotary flange into the magnetite filter where particles in the incoming water are set in rotation by the splitter (3) and, as in a centrifugal unit, carried to the unit's outer wall where they sink to the unit floor. Here they are collected and flushed out through the ball valve (4) (see chapters “Rinsing” and “Rinse interval”). Gases present in the water gather in the upper chamber of the unit and are released out through the integrated aeration system.

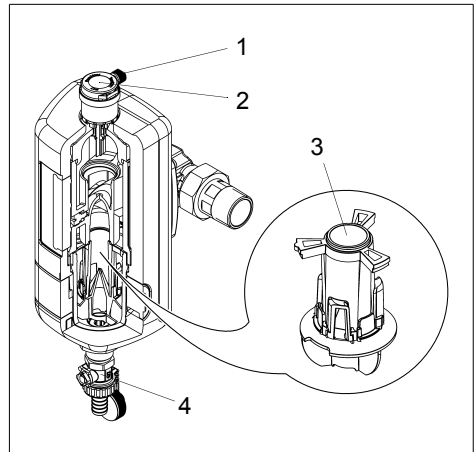

Fig. 5: Centrifugal separator

- 1 Cover cap
- 2 Aeration unit
- 3 Splitter
- 4 Ball valve

## Magnetic separator

Magnetite sludge ( $\text{Fe}_3\text{O}_4$ ) present in a closed loop heating or cooling system can result in malfunction of individual systems components, massive loss of operating efficiency and, worst case, systems failure.

With its three high efficiency magnets (1) the magnetite filter ensures that magnetic sludge (2) is trapped and then physically removed from the system by regular rinsing (see fig. 6).

Before rinsing, close the shut-off valve downstream of the magnetite filter, then pull the magnet holder on the front of the unit towards you to allow the sludge collected there to drop to the unit floor (see chapter "Cleaning the magnetic separator"). A rinse may then be carried out (see chapters "Rinsing" and "Rinse interval"). The magnetite filter operates in a constant flow rate and causes only a small pressure loss.

High levels of oxygen concentration can also be found in closed loop systems. Weak points within the system (e.g. non diffusion resistant plastic pipes or membranes) mean that  $\text{O}_2$  can enter the system on an ongoing basis. In combination with water, this results in surface corrosion successively removing material. The rate of this corrosion progress is mainly determined by the factors  $\text{O}_2$  content and time. Systems containing sludge so formed are not only more liable to malfunction, but also operate at much lower efficiency levels. The water quality within such systems is often unstable and, especially where movement is less volatile, at the upper limits of requirements. A result of this may be corrosion (pitting) and resulting leakage. Sludge deposits greatly affect the rate of heat transfer. Although the performance data is constantly dropping, the actual cause of the problem is often not recognised until it is too late.

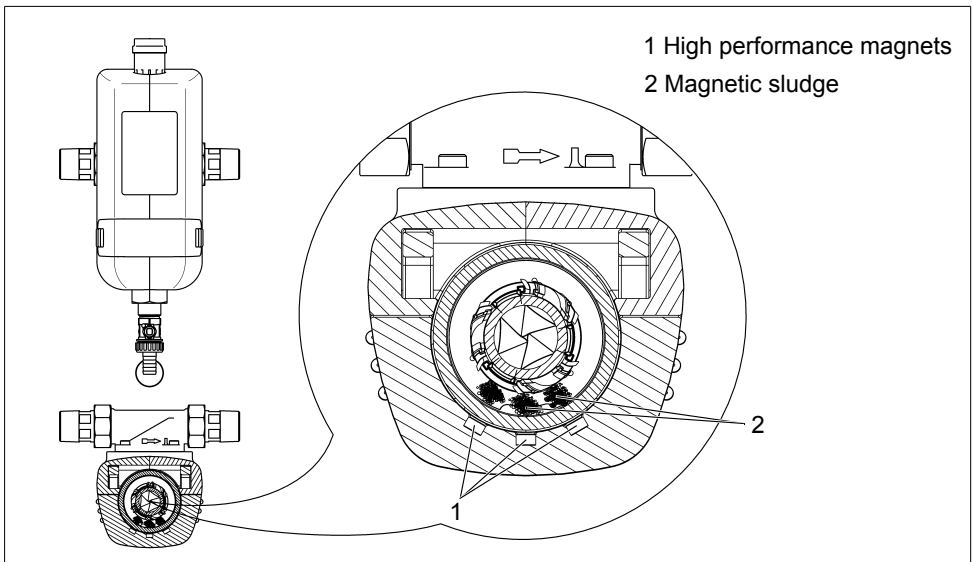

Fig. 6: Magnetic separator in operation

### 5.3 Cleaning the magnetic separator

The magnetic separator is used to retain magnetic sludge in the unit, and this is then permanently removed from the system by regular rinsing (see chapter "Rinsing"). The shut-off valve downstream of the filter must be closed before rinsing.

The black magnet holder in the front of the unit is then pulled fully open to allow the sludge retained to drop to the unit floor (see fig. 7).

The draw may be closed again after approx. 10 seconds and the unit rinsed (see chapter "Rinsing").

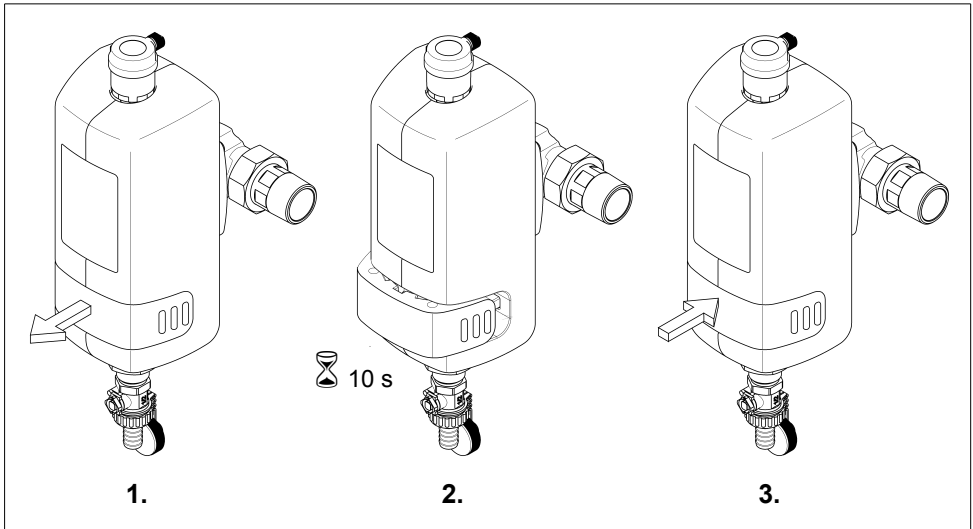

Fig. 7: Cleaning the magnetic separator

**i** Failure to close the shut-off valve downstream of the filter before cleaning will result in sludge being returned to the heating loop.

## 5.4 Rinsing

In order to remove sludge and particles from the system, the magnetite filter must be rinsed at regular intervals.

Refer to chapter "Dangers during rinsing" before commencing!

In order to obtain an optimal unit rinse, first close the shut-off valve downstream of the filter. To rinse open the ball valve at the bottom of the unit. Observe the following:

The filter comes delivered with the ball valve closed and capped. Before opening the ball valve, remove the cap (1), then insert the spout (2) and fix it in place with the union nut (3). The ball valve may now be opened by means of the cap (see fig. 8).

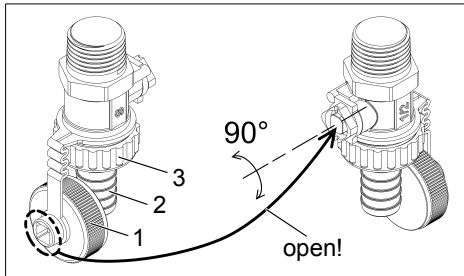

Fig. 8: Safety ball valve

### Danger of scalding!

During rinsing heating water flows through the filter, washing sludge and particles collected on the unit floor out through the ball valve. After 2 - 3 ltrs. of water have run through, the ball valve must be firmly closed.

Re-open the shut-off valve downstream of the unit once rinsing is complete.

Check the systems pressure after rinsing as a top up may be required.

A top up will then bring the unit back to the correct operating pressure and, where no automatic fill system is available, be carried out manually. Pressure levels in the system and in the expansion vessel should be set before commissioning the magnetite filter and checked and adjusted at least once per year.

## 5.5 Rinse interval

Where retrofitted into an existing system, the magnetite filter should be rinsed at least every 14 days until the water removed becomes visibly clearer. After that, as with new installations, once at heating start up and once when the system is shut down is enough.

## 5.6 Modifications / changes / spare parts



(see chapter "Safety information and dangers due to non-compliance")

Only original spare parts are to be used! Arbitrary modifications and changes are prohibited for safety reasons! They can impair the function of the magnetite filter and lead to leaks.

### 5.6.1 Servicing / repair

Before carrying out any work on the magnetite filter, which extends beyond pure operational control, the system must be depressurised! Allow the magnetite filter to cool down first! Failure to observe this can lead to an uncontrolled escape of water and therefore lead to scalding and water damage in the building. Strictly comply with the instructions given in the “Installation” and “Maintenance” chapters.

### 5.7 Stoppages



(see chapter “Safety information and dangers due to non-compliance”)

If a magnetite filter has to be removed from the flange or unscrewed, the chapter “Intended use” must always be observed!

- Protect the flange surfaces from damage! Damaged flange surfaces cannot close tight any longer. As a result, escaping water can damage the building and installations.
- Store the magnetite filter in frost-free conditions! Frost can cause any water contained in the magnetite filter's voids to freeze and thus cause mechanical damage to the magnetite filter so that it leaks at operating pressure or can burst. Leaking water can cause major damage to the building. In addition, people near the magnetite filter can be injured by breaking off filter parts.
- When restarting the magnetite filter, follow the instructions for a new magnetite filter.

## 6. Faults

The opening of the units and the replacement of the water pressure charged parts may only be effected by authorized personal in order to ensure the unit security and its tightness.

### Help with faults:

Fault	Cause	Remedy
Heating is cold.	A shut-off valve has not been reopened.	Open shut-off valve!
	A defect in the circulation pump.	Inform the fitter or nearest customer service centre!
No rinse water.	The heating system or expansion vessel is pressureless.	Top up required heating water! Check expansion vessel!
	A backflow preventor, gravity brake or automatic shut-off unit are installed between the magnetite filter and the expansion vessel in flow direction.	Open shut of unit or re-align place of installation for magnetite filter more favourably!
	In gas fired systems, shut down often occurs automatically when operating temperature of the heating water has not yet been reached.	Wait for correct water temperature!
Rinse water very dirty.	Rinse intervals are too long.	Reduce rinse intervals!
Magnetite filter leaks.		Inform the fitter or nearest customer service centre!



## 7. Maintenance



(see chapter “Safety information and dangers due to non-compliance”)

Always observe the chapter “Intended use”!

### 7.1 Cleaning



(see chapter “Safety information and dangers due to non-compliance”)

**Use only clear, drinking water for cleaning.**

Domestic all-purpose cleaners and glass cleaners can contain up to 25 % solvents or alcohol (spirits).

These substances can chemically attack the plastic parts, which can lead to brittleness or even fractures.

**These kinds of cleaners must therefore not be used.**

## 8. Warranty and services

In order to comply with the legal warranty claim, a visual check and rinse of the unit must be carried out at least once at the beginning and end of the heating period. Where the heating water has a heavy dirt load, then the rinse should be carried out every 2 weeks until a noticeable increase in clarity has been reached.

## 9. Data sheet

### 9.1 Type

JUDO MAFI  
Magnetite filter

Abbreviated name: JMFI

### 9.2 Models

Model	Order no.
JMFI ¾"	8060083
JMFI 1"	8060084
JMFI 1¼"	8060085
JMFI 1½"	8060086

### 9.3 Technical specifications

For all types:

- Max. water temperature 90 °C (194 °F)
- Threaded connection according to DIN EN 10226-1

### Nominal pressure

Model	Operating pressure	Nominal pressure
JMFI	1 – 6 bar	PN 6

### Weight

Model	Weight
JMFI ¾"	2.1 kg
JMFI 1"	2.3 kg
JMFI 1¼"	2.8 kg
JMFI 1½"	8,4 kg

### Water flow rate

Model	Nominal flow rate	Pressure loss at nominal flow
JMFI ¾"	1 m³/h	0.04 bar
JMFI 1"	1.5 m³/h	0.07 bar
JMFI 1¼"	2 m³/h	0.15 bar
JMFI 1½"	4 m³/h	0,15 bar

### Rinse volume stream

Model	Rinse volume stream
JMFI ¾" - 1¼"	0.2 - 0.4 l/s
JMFI 1½"	0,4 - 0,8 l/s

The given rinse volume stream applies to 2 bar water pressure and for a completely opened ball valve.

## 9.4 Installation dimensions

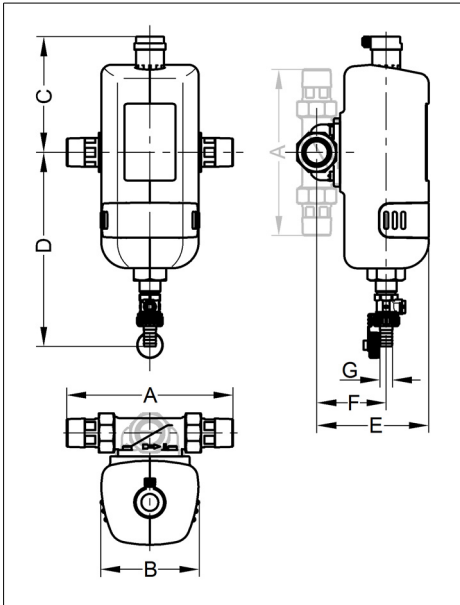

Fig. 9 : Installation dimensions JMFI 3/4" - 1 1/4"

Model	A	B	C	D	E	F	G
JMFI 3/4"	180	116	141	227	131	82	15
JMFI 1"	195	116	141	227	131	82	15
JMFI 1 1/4"	230	116	141	227	136	87	15

All dimensions in [mm] (see fig. 9)

- A = Fitting length
- B = Unit width
- C = Height above pipe centre
- D = Height below pipe centre
- E = Depth to pipe centre
- F = Waste water connection centre to pipe centre
- F1 = Distance waste water connection centres
- G = Connection dimension waste water

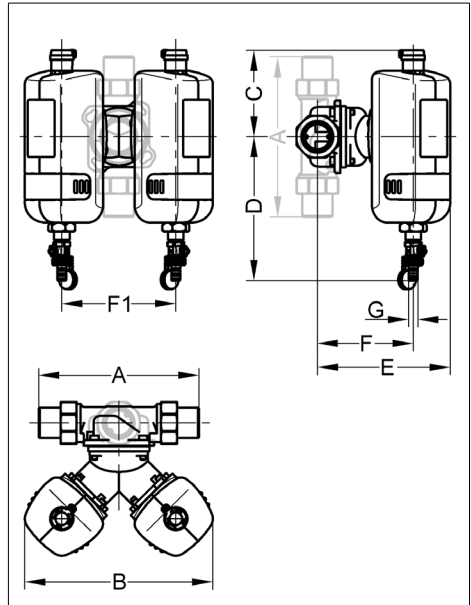

Fig. 10 : Installation dimensions JMFI 1 1/2"

Model	A	B	C	D	E	F	F1	G
JMFI 1 1/2"	252	296	141	227	209	151	180	15

All dimensions in [mm] (see fig. 10)

## 9.5 Scope of supply

- Pre-mounted magnetite filter
- Installation and operating instructions

## 9.6 Accessories

- Heating resupply station JHF-F PLUS (order no. 8060080)

The JUDO HEIFI-FÜL PLUS heating resupply station consists of two integrated shut-off valves, pressure regulator, manometer and pipe disconnecter, type BA. The integrated pressure regulator ensures that the pressure in the system remains constant and, should this drop, then a top up with water is effected automatically.

## 10. Spare parts

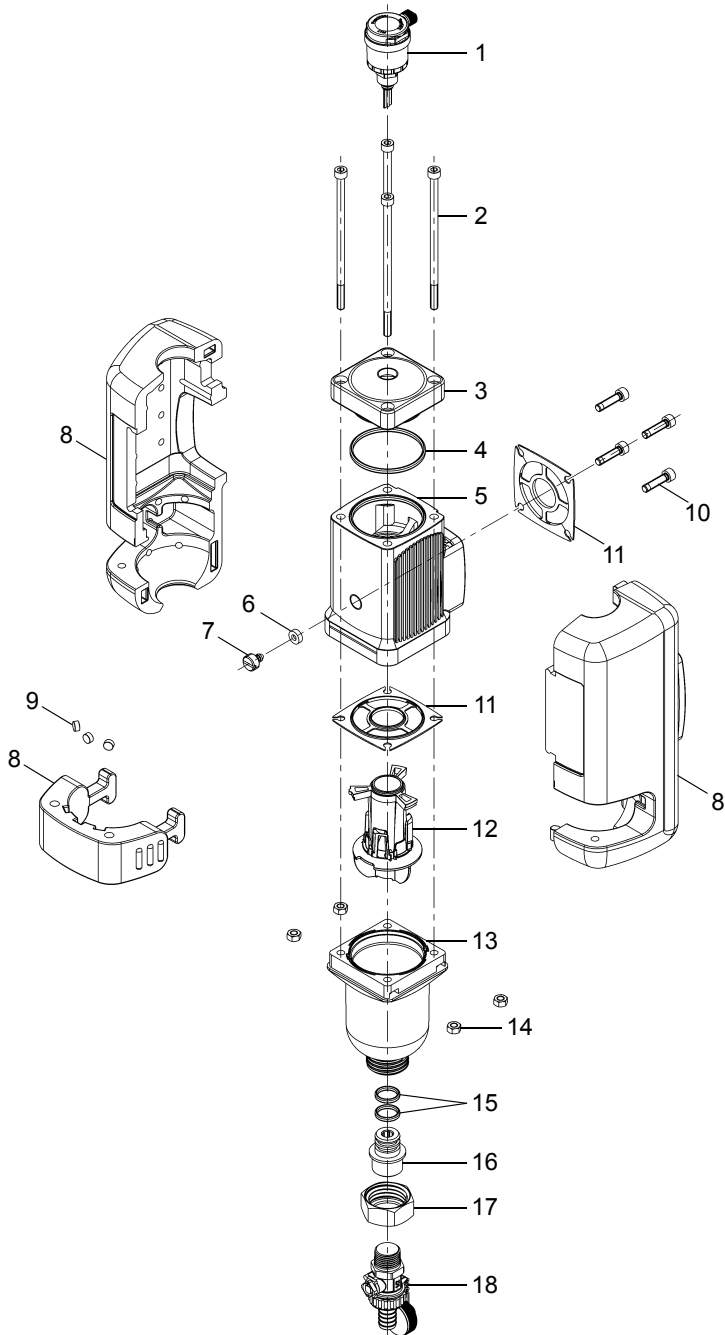

## List of spare parts JMFI

Item	Designation (recommended average replacement interval for wearing parts [**])	Piece(s)	Order no.	AU <sup>1)</sup> / piece
--	Wearing parts set "Seals" (consisting of items 4, 6, 11, 15) ****	1	2060388	17
--	Spare parts set "Aeration unit" (consisting of items 1)	1	2060390	38
--	Spare parts set "Casing" (consisting of items 8, 9)	1	2060386	46
--	Spare parts set "Ball valve" (consisting of items 15, 16, 17, 18)	1	2060456	VE <sup>2)</sup>
1	Aeration unit	1		
2	Cylinder screw M6x130 (set of 4 pcs)	1	2060462	6
3	Upper cover	1	2060452	VE <sup>2)</sup>
4	O-ring 52x3,5	1		
5	Base unit	1	2060458	VE <sup>2)</sup>
6	Seal	1		
7	Stopper	1	2060450	6
8	Set of insulating shells	1		
9	Round magnet	3		
10	Cylinder screw M6x25 (set of 4 pcs)	1	2060446	2
11	Profiled flange gasket	2		
12	Splitter, complete	1	2060454	VE <sup>2)</sup>
13	Filter bowl	1	2060460	VE <sup>2)</sup>
14	Hexagon nut M6 (set of 4 pcs)	1	2060448	VE <sup>2)</sup>
15	O-ring 16x2,5	2		
16	Adapter fitting	1		
17	Union nut	1		
18	Safety ball valve	1		

1) AU = accounting unit (Items without AU are only available in a set.)

2) Accounting unit not specified at the time of going to press.

Replacement interval: \*\*\*\* = 4 years





## 11. Customer service



### JUDO Wasseraufbereitung GmbH

Postfach 380 • D-71351 Winnenden  
Tel. +49 (0)7195 / 692-0  
e-mail: info@judo.eu • judo.eu



### JUDO Wasseraufbereitung GmbH • Niederlassung Österreich

Zur Schleuse 5 • A-2000 Stockerau  
Tel. +43 (0)22 66 / 6 40 78 • Fax +43 (0)22 66 / 6 40 79  
e-mail: info@judo-online.at • judo-online.at



### JUDO Wasseraufbereitung AG

Industriestrasse 15 • CH-4410 Liestal  
Tel. +41 (0)61 906 40 50 • Fax +41 (0)61 906 40 59  
e-mail: info@judo-online.ch • judo-online.ch



### JUDO Wasseraufbereitung GmbH • Filiaal-Filiale BeNeLux

Laarbeeklaan-Av. du Laerbeek, 72 A1 • B-1090 Brussel-Bruxelles  
Tel./Tél. +32 (0)24 60 12 88 • Fax +32 (0)24 61 18 85  
e-mail: info.benelux@judo.eu • judo.eu



### JUDO France S.à.r.L

76 Rue de la Plaine des Bouchers (Technosud) • F-67100 Strasbourg  
Tel. +33 (0)3 88 65 93 94 • Fax +33 (0)3 88 65 98 49  
e-mail : info@judo.fr • judo.fr

Installed by:

<p><b>JUDO PROFI-PLUS / PROMI</b> Backwash protective filter / domestic water station of the germ protection class with point rotation system for optimum cleaning of the filter insert.</p>	<p><b>JUDO QUICK-DOS</b> The secondly-quick heating protection out of the tin. Cleans and protects - for better function.</p>	<p><b>JUDO HEIFI-FÜL</b> Heating resupply station for compliance with DIN EN 1717, ideal in combination with JUDO HEIFI-TOP.</p>
<p><b>JUDO BIOSTAT-COMBIMAT</b> The anti-lime protection and hygiene unit to be used in domestic water installations. Stops lime - without replacing the cartridge - and fights germs.</p>	<p><b>JUDO JULIA</b> Metering pump for JUL mineral solution against corrosion (brown water) and lime deposits.</p>	<p><b>JUDO i-soft TGA 2</b> The world's first automatic, intelligent water softener.</p>

All illustrations, dimensions and information for the different models are those valid on the date of printing. All rights are reserved for modifications as a result of technical progress or further developments. Claims with regard to models or products are excluded.

1702868 • 2017/07